

ABC's of Spray Finishing \$10.00 1-239-D 04/06

ABC's of Spray Finishing



BINKS

DEVILBISS

Forward

While this book examines the spray finishing operation and its equipment from many viewpoints, there is still much more to be learned to become truly proficient at spray finishing.

The best way to become proficient at spray finishing is to just do it! Many trade technical and community colleges offer courses in spray finishing, a great way to improve your skills.

Many of the “tricks” of the professional spray finisher involve paints and coatings. The manufacturers of these materials routinely publish complete books on these subjects. These publications are available in specialty paint stores and will provide you with considerable detail. Many of these books also contain information on techniques for surface preparation.

Another important source of information, particularly on equipment use and selection is your local spray finishing equipment distributor. No book could ever completely cover a specialist’s in-depth knowledge of the equipment, the techniques, the maintenance and troubleshooting.

Information is available from many resources on the subject of spray finishing. It is our hope that this book provides you with a start toward perfecting your finishing skills.

A recent addition to resources available to the spray finisher is the World Wide Web. Many manufactures are represented and question and answer forums are available. Please visit our websites at www.devilbiss.com or www.binks.com.

About this book.....

This book has been updated several times from “The ABC’s of Spray Equipment,” originally published by The DeVilbiss Company in 1954. It focuses on equipment and techniques for spray finishing.

The format of the original book was question-and-answer. We have retained that format in this edition.

This book is organized around the major components of an air spray system... spray guns, material containers, hose, air control equipment, compressors, spray booths, respirators and a short section on general cleanliness and other sources of information. A thorough understanding of the material in this book - plus a lot of actual spray painting practice - should enable you to handle just about any spray painting situation.

Although we have made an effort to make this book as detailed and as complete as possible, be aware that the equipment and product systems used to illustrate points are entirely based on DeVilbiss and Binks technology. DeVilbiss and Binks are two of the world’s oldest and largest manufacturer of spray painting equipment, and have maintained this leadership since its founding in 1888.

Table of Contents

Forward	2
1. Introduction	3
Surface Preparation.....	3
Paint Preparation.....	3
2. Air Atomizing Spray Guns 4	
Spray Gun Types	4
Part Identification and Function.....	6
Operation	9
Maintenance	11
Troubleshooting	13
3. Material Containers.....	16
4. Hose and Connections ...	18
5. Air Control Equipment.....	20
6. Respirators	22
7. Air Compressors.....	23
8. Spray Booths	24
9. Diaphragm Pumps	27
10. High Pressure Spraying .	29
11. H.P. Spray Guns	30
12. Two Ball Piston Pumps .	31
13. H.P. equipment setup....	32
14. Four Ball Piston Pumps .	33
15. Circulating Systems	34
16. H.P. Troubleshooting ...	36

Introduction

This book is about the selection, use and maintenance of finishing equipment: spray guns, tanks, cups, hoses, compressors, regulators, spray booths, respirators, etc. It presumes that you are familiar with standard surface preparation techniques that may be required before finishing actually begins. It also presumes a basic knowledge of the many different types of paints and coatings available.

Creating a perfect finish requires a solid knowledge of surface preparation, finishes and spray painting equipment. The first two are extensively covered in many other books. The manufacturers of paints and coatings have gone to great length to publish information on their new and existing products.

But, even an extensive knowledge of surface preparation techniques and paint chemistry is not enough to assure a professional finish. The finish must be applied by a spray gun, and all the variables of its use must be mastered.

The equipment necessary to apply the finish – the spray gun, tank, cup, regulator, hoses, compressor, etc. – must all be matched to the job as well as to each other. That equipment must be used and maintained properly, with an appreciation of how and why it works the way it does.

The moment of truth for any finish happens when the trigger is pulled. This book focuses on that moment.

Surface Preparation

The surface to be finished should be well cleaned before painting. If the paint manufacturer's instructions call for it, the surface should be chemically treated. Use a blow-off gun and tack rag to remove all dust and dirt. No amount of primer or paint will cover up a badly prepared surface.

Plastic parts may contain static electricity from the molding process.

This static attracts particles of dust and dirt. Eliminate them by treating with "destatisizing" air using a special blow-off gun that imparts a neutral charge to the airflow.

Paint Preparation

Today's finishes are extremely complex chemical formulations. They include both solvent and waterborne types. Some may require the addition of solvents to form the proper spraying viscosity. Others may simply require the addition of a second component at a prescribed ratio to obtain sprayable consistency. Many of them also have hardeners or other chemicals, added to them to insure correct color match, gloss, hardness, drying time or other characteristics necessary to produce a first class finish. Make sure you are familiar with the specific finish material data sheets accompanying each material. Do not mix materials from various manufacturers. Read and follow directions carefully.

All finish materials must also be supplied with material Safety Data sheets (MSDS). This data provides information on proper handling and disposal of materials. Many states require that MSDS be kept on file by the user.

The first step is knowing the type and color of paint the project requires.

With these determined, follow the manufacturer's instruction for preparing it exactly. If you have any doubts about how to proceed, don't guess! Contact your paint supplier for help. Improperly prepared paint will never produce a good finish!

The chief characteristic that determines the sprayability of paint and how much film may be applied, is its viscosity ... or consistency. Following the paint manufacturer's instructions will get you close, but for professional results, use a viscosity cup. It is a simple but very accurate, way to measure the thickness of paint. With the cup, you can thin or reduce the paint to the

precise consistency required by the manufacturer.

Always prepare paint in a clean, dust-free environment. Paint has a remarkable ability to pick up dirt. Dirty paint will not only clog your spray gun, but it will also ruin your paint job. Get in the habit of always pouring paint into the cup or tank through a paint strainer. Paint is never as clean as it looks.

2. Air Atomizing Spray Guns

Introduction

The spray gun is the key component in a finishing system. It is a precision engineered and manufactured instrument. Each type and size is specifically designed to perform a certain, defined range of tasks.

As in most other areas of finishing work, having the right tool for the job goes a long way toward getting professional results.

This chapter will help you know which is the proper gun by reviewing the Conventional Air and High Volume/Low Pressure spray gun designs commonly used in finishing - siphon feed, gravity feed and pressure feed. It will also review the different types of guns and components within each design.

A thorough understanding of the differences between systems will allow you to select the right gun, to use it properly to produce a high quality finish and to contribute toward a profitable finishing operation.

SPRAY GUN TYPES

1. What is an air atomizing spray gun?

Air atomizing spray guns are available in two types: Conventional Air Spray and High Volume Low Pressure (HVLP).

Conventional air spray guns pass virtually all the input pressure to the air cap. HVLP reduces the air pressure internally to a much lower pressure (see para. 8).

Conventional air spray guns are usually lower in efficiency than HVLP.

Air and material enter the gun through separate passages, and are mixed at the air cap in a controlled pattern.

2. What are the types of air spray guns?

Air spray guns may be classified in various ways. One way is by the location of the material container:

Figure 1 shows a gun with a cup attached below it.

Figure 3 shows a gun with a cup attached above it.

Figure 4 shows a material container some distance away from its pressure feed gun.

The type of material feed system is also a way of classifying guns:

Siphon Feed... draws material to the gun by siphoning as in Figure 1.

Gravity Feed... the material travels down, carried by its own weight and gravity as in Figure 3.

Pressure Feed... the material is fed by positive pressure as in Figure 4.

Guns may also be classified as either external or internal mix.

3. What is a suction feed gun?

A spray gun design in which a stream of compressed air creates a vacuum at the air cap, providing a siphoning action. Atmospheric pressure on the material in the suction cup forces it up the pickup tube, into the gun and out the fluid tip, where it is atomized by the air cap. The vent holes in the cup lid must be open. This type gun is usually limited to a one-quart, or smaller, capacity container.

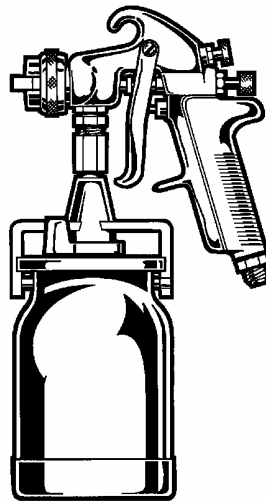

Figure 1- Siphon Feed Gun with attached cup

Suction feed is easily identified by the fluid tip extending slightly beyond the face of the air cap, as shown in Figure 2.

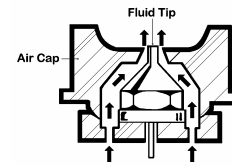

Figure 2 - Suction Feed Air Cap

Suction feed guns are suited to many color changes and to small amounts of material, such as in touchup or lower production operations.

4. What is a gravity feed gun?

This design uses gravity to flow the material from the cup, which is mounted above the gun, into the gun for spraying. No fluid pickup tube is used, since the fluid outlet is at the bottom of the cup.

This cup has a vent hole at the top of the cup which must remain open. It is limited to 32 ounce capacities due to weight and balance.

Gravity feed guns are ideal for small applications such as spot repair, detail finishing or for finishing in a limited space. They require less air than a siphon feed gun, and usually have less overspray.

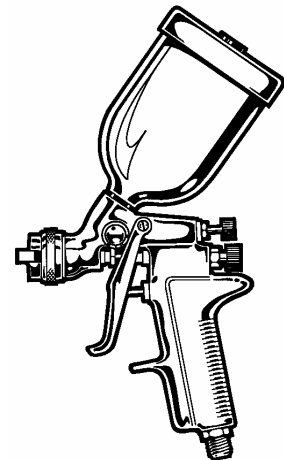

Figure 3- Gravity Feed Gun with attached cup

2. Air Atomizing Spray Guns

Pro Tip:

When using a gravity feed system, downsize the tip one size from suction. If the siphon system calls for a .070", use a .055 or .062"

5. What is a pressure feed gun?

In this design, the fluid tip is flush with the face of the air cap (see Figure 5). The material is pressurized in a separate cup, tank or pump. The air pressure forces the material through the fluid tip and to the air cap for atomization.

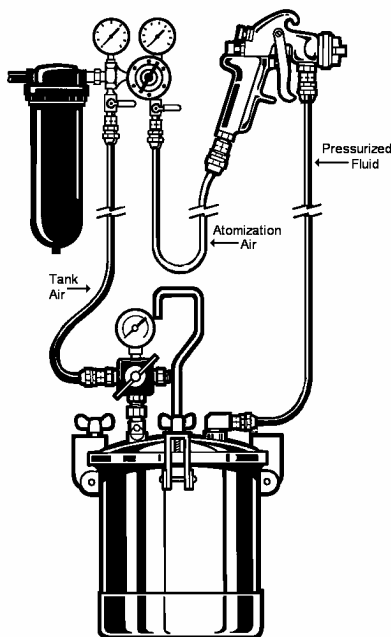

Figure 4 - Typical Pressure Feed Gun with remote tank

This system is normally used when large quantities of material are to be applied, when the material is too heavy to be siphoned from a container or when fast application is required. Production spraying in a manufacturing plant is a typical use of a pressure feed system

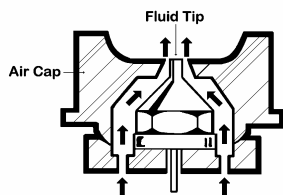

Figure 5 - Pressure Feed Air Cap

Type	Viscosity	Fluid	Atomizing	Type
Feed	(#2 Zahn)	Oz/Minute	Pressure	Production
Siphon	up to 24	10-12	40-50	Low
Gravity	up to 24	10-12	30-40	Low
Pressure	up to 29	20-24	50-60	High
HVLP	up to 29	14-16	10	High

Table 1

6. What is an external mix gun?

This gun mixes and atomizes air and fluid outside the air cap.

It can be used for applying all types of materials, and it is particularly desirable when spraying fast drying paints such as lacquer. It is also used when a higher quality finish is desired.

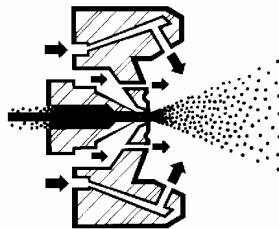

Figure 6 - External Mix Gun

7. What is an internal mix cap?

This gun mixes air and material inside the air cap, before expelling them.

It is usually used where low air pressures and volumes are available, or where slow-drying materials are being sprayed.

A typical example is spraying flat wall paint, or outside house paint, with a small compressor.

Internal mix guns are rarely used for finishing when a fast-drying material is being sprayed, or when a high quality finish is required.

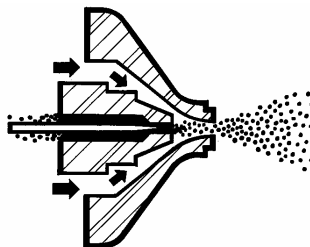

Figure 7 - Internal Mix Gun

8. What is HVLP?

HVLP, or High-Volume/Low Pressure, uses a high volume of air (typically between 15-26 CFM) delivered at low pressure (10 PSI or less at the air cap) to atomize paint into a soft, low-velocity pattern of particles.

In most cases, less than 10 psi is needed in order to atomize.

Proper setup utilizes no more fluid and air pressure than is needed to produce the required quality and a flow rate that will meet production requirements.

As a result, far less material is lost in overspray, bounceback and blowback than with conventional air spray. This is why HVLP delivers a dramatically higher transfer efficiency (the amount of solids applied as a percent of solids sprayed) than spray systems using a higher atomizing pressure.

The HVLP spray gun resembles a standard spray gun in shape and operation. Models that use high inlet pressure (20-80 psi) and convert to low pressure internally within the spray gun are called HVLP conversion guns.

Some HVLP models, particularly those using turbines to generate air, bleed air continuously to minimize back-pressure against the air flow of the turbine.

The air cap design is similar to that of a standard spray gun, with a variety of air jets directing the atomizing air into the fluid stream, atomizing it as it leaves the tip.

HVLP is growing in popularity and new environmental regulations are requiring it for many applications.

HVLP can be used with any low-to-medium solids materials that can be atomized by the gun, including two-component paints, urethanes, acrylics, epoxies, enamels, lacquers, stains, primers, etc.

PART IDENTIFICATION FUNCTION

9. What are the principal parts of a spray gun?

2. Air Atomizing Spray Guns

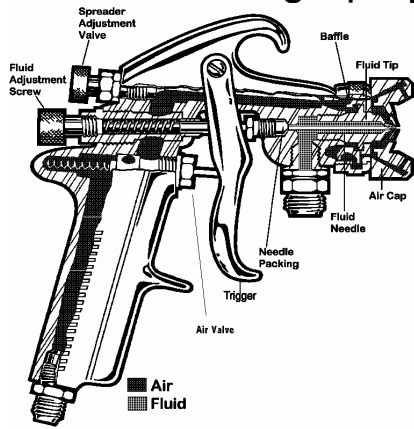

Figure 8 - The Anatomy of a Spray Gun

10. What happens when the trigger is pulled?

The trigger operates in two stages. Initial trigger movement opens the air valve, allowing atomizing air to flow through the gun.

Further movement of the trigger opens the fluid needle, allowing fluid material to flow. When the trigger is released, the fluid flow stops before the atomizing air flow.

This lead/lag time in the trigger operation, assures a full spray pattern when the fluid flow starts. It also assures a full pattern until the fluid flow stops, so there is no coarse atomization.

11. What is the function of the air cap?

The air cap (see Figure 10) directs compressed air into the fluid stream to atomize it and form the spray pattern. (see Figure 9)

Round Tapered Blunt

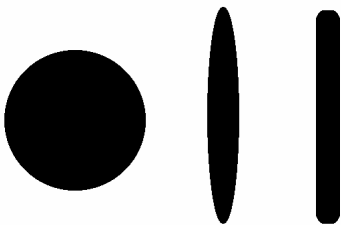

Figure 9 - Types of Spray Patterns

There are various styles of caps to produce different sizes and shapes of patterns for many applications.

12. What are the advantages of the multiple jet cap?

This cap design provides better atomization of more viscous materials.

It allows higher atomization pressures to be used on more viscous materials with less danger of split spray pattern.

It provides greater uniformity in pattern due to better equalization of air volume and pressure from the cap.

It also provides better atomization for materials that can be sprayed with lower pressures.

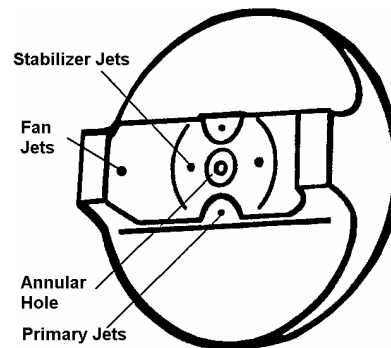

Figure 10 - External Mix Air Cap

13. How should an air cap be selected?

The following factors must be considered:

- a) Type, viscosity and volume of material to be sprayed
- b) size and nature of object, or surface, to be sprayed (Multiple, or larger, orifices increase ability to atomize more material for faster painting of large objects.

Fewer, or smaller, orifices usually require less air, produce smaller spray patterns and deliver less material. These caps are designed for painting smaller objects and/or using slower speeds.

- c) material feed system used - pressure, siphon or gravity

- d) size of fluid tip to be used (Most air caps work best with certain fluid tip/needle combinations.)

e) volume of air in cubic feet per minute (cfm) and pressure in pounds per square inch (psi) available

See the **DeVilbiss** or **Binks** spray gun catalog for the proper selection of air cap / fluid tip / needle combinations and typical uses.

14. What is the function of the fluid tip and needle?

They restrict and direct the flow of material from the gun into the air stream. The fluid tip forms an internal seat for the tapered fluid needle, which reduces the flow of material as it closes. (see Figure 11)

The amount of material that leaves the front of the gun depends upon the viscosity of the material, the material fluid pressure and the size of the fluid tip opening provided when the needle is unseated from the tip.

Fluid tips are available in a variety of sizes to properly handle materials of various types, flow rates and viscosity's.

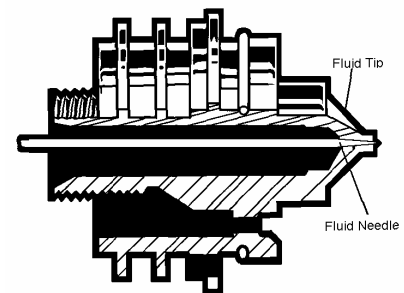

Figure 11 - The Fluid Tip and Needle

15. What is the nozzle combination?

In practice, the air cap, fluid tip, needle and baffle are selected as a unit, since they all work together to produce the quality of the spray pattern and finish. These four items, as a unit, are referred to as the nozzle combination.

2. Air Atomizing Spray Guns

16. What are the standard fluid tip sizes and flow rates?

The standard sizes, corresponding fluid tip opening dimensions and flow rates are:

Conventional Air Spray

Fluid Tip I.D.	Flow Rate/ Material
Pressure Feed Systems	
.028"/.7mm	up to 12 oz/min
.0425"/1.1mm	up to 20 oz/min
.055"/1.4mm	up to 30 oz/min
.070"/1.8mm	over 30 oz/min
.070"/1.8mm	porcelain enamel
.086"/2.2mm	heavy body materials
.110"/2.75mm	heavy body materials
Siphon Feed Systems	
.070"/1.8mm	up to 12 oz/min
.062"/1.6mm	up to 10 oz/min
Gravity Feed Systems	
.055"/1.4mm	up to 30 oz/min
.062"/1.6mm	up to 30 oz/min

Table 2

HVLP

Fluid Tip I.D.	Flow Rate/ Material
Pressure Feed Systems	
.0425"/1.1mm	up to 10 oz/min
.055"/1.4mm	up to 14 oz/min
.070"/1.8mm	up to 20 oz/min
.086"/2.2mm	over 20 oz/min
Siphon Feed Systems	
.086"/2.2mm	up to 9 oz/min
.070"/1.8mm	up to 8 oz/min
Gravity Feed Systems	
.055"/1.4mm	up to 12 oz/min
.062"/1.6mm	up to 12 oz/min

Table 3

Rule of thumb

Optimum fluid pressures are 8-20 psi. Pressures greater than this generally indicate the need for a larger fluid tip size.

17. How are fluid tip and needle sizes identified?

DeVilbiss and Binks fluid tips and needles are identified by the letters or numbers stamped on the tip and the needle.

The identification letters on these components should match. See the appropriate DeVilbiss/Binks spray gun catalog for the proper selection of fluid tip and needle combinations.

18. What fluid tip and needle combination sizes are most common?

.042/1.1mm, .055/1.4mm and .070/1.8mm are most commonly used. The .070/1.8mm size is used for suction feed, while .055/1.4mm and .062/1/6 are used for gravity Feed. For pressure feed the most common tips are .042/1.1mm, .055/1.4mm and .070/1.8mm,

19. How are nozzle combinations selected?

Five basic considerations are involved in selecting the nozzle combination:

- type and viscosity of material being sprayed
- physical size of object being finished
- desired speed/finish quality
- gun model being used
- available air volume (cfm) and pressure (psi) from compressor

(1) The type and viscosity of the material being sprayed is the first factor to consider.

Rule of thumb

The lower the viscosity of the material, the smaller the I.D. of the fluid tip.

Material Viscosity	Flow Rate	Tip Size
#2 Zahn		
up to 23 sec	Low	.0425"/1.1mm
23-28 sec	Med	.055"/1.4mm
28-48 sec	High	.070"/1.8mm
over 48 sec	High	.086"/2.2mm

Table 4

NOTE: Viscosity conversion charts are available to convert one viscosity cup reading to another from any material or equipment supplier.

(2) The physical size of the object to be painted must also be considered. As a general rule, use the largest possible spray pattern consistent with the object size. Remember that different air caps deliver various pattern characteristics. This can reduce both spraying time and the number of gun passes.

(3) The next consideration in evaluating nozzle combinations is the speed with which the finish will be applied, and the desired level of quality.

For speed and uniform coverage, choose a nozzle combination which produces a pattern as wide as possible.

For finish coat work, quality is the deciding factor. Choose a nozzle combination which produces a fine atomization and a smaller pattern size, thereby giving greater application control.

(4) The model of the gun itself will limit the selection of nozzle combination.

For a suction feed gun, there are two nozzle types available which are suitable for finishing operations. These nozzles have fluid tip openings of .070"/1.8mm to .086"/2.2mm, and are designed to handle viscosities up to 28 seconds in a No. 2 Zahn Viscosity Cup.

For a pressure feed gun, the amount of material discharged depends upon material viscosity, the inside diameter of the fluid tip, the length and size of hose and the pressure on the material container or pump.

2. Air Atomizing Spray Guns

If the fluid tip opening is too small, the paint stream will be too high. If the fluid tip opening is too large, you will lose control over the material discharging from the gun.

For most HVLP guns, the paint flow shouldn't exceed 16 oz. per minute. For recommended flow rates for each fluid tip size, consult the DeVilbiss or Binks catalog.

(5) Available air supply is the last factor to consider.

Pressure feed air caps consume between 7.0 and 26.0 CFM, depending on air pressure applied. If your air supply is limited, because of an undersized compressor, or many other air tools are in use at once, the gun will be starved for air, producing incomplete atomization and a poor finish.

20. What are the criteria for selecting a pressure feed nozzle?

While the fluid discharge in ounces per minute from a suction feed gun is relatively stable (largely because it is determined by atmospheric pressure), the fluid discharge from a pressure feed gun depends more upon the size of the inside diameter of the fluid tip and the pressure on the paint container or pump. The larger the opening, the more fluid is discharged at a given pressure.

If the fluid tip ID is too small for the amount of material flowing from the gun, the discharge velocity will be too high. The air, coming from the air cap, will not be able to atomize it properly causing a center-heavy pattern.

If the fluid tip opening is too large, material discharge control will be lost, often resulting in a split pattern.

The fluid tip/air cap combination must be matched to each other and to the job at hand. Spray gun catalogs include charts to help you match them properly.

21. Of what metals are fluid tips made?

Tips are made of the following metals:

- a) 300-400 grade stainless steel for both non-corrosive and corrosive materials
- b) Carboly inserts for extremely abrasive materials

23. What is viscosity?

The viscosity of a liquid is its body, or thickness, and it is a measure of its internal resistance to flow. Viscosity varies with the type and temperature of the liquid. Any reference to a specific viscosity measurement must be accompanied by a corresponding temperature specification.

Viscosity is usually measured in poise and centipoise (1 poise=100 centipoise). The most common measurement used to determine viscosity in finishing is *flow rate* (measured in seconds from a Zahn, Ford or Fisher Viscosity Cup).

Viscosity conversion may be accomplished by consulting a viscosity conversion chart.

Different viscosity cup sizes are used for different thicknesses of materials. Each cup has a precision hole at the bottom of the cup. Use a smaller or larger hole in the cup depending on the thickness of the material.

Viscosity control is an extremely important and effective method to maintain application efficiency and quality consistency. Always measure viscosity after each batch of material is mixed and make sure material temperature is the same, normally 70° to 90° F.

Consult your coatings Technical Data Sheet for temperature recommendations.

23. What is the spreader adjustment valve?

A valve for controlling the air to the horn holes which regulate the spray pattern from maximum width down to a narrow or round pattern. (See Figure 8)

24. What is the fluid needle adjustment?

This adjustment controls the travel of the fluid needle, which allows more or less material through the fluid tip. See Figure 8.

With pressure feed systems, the fluid delivery rate should be adjusted by varying the fluid pressure at the pressure pot. Use the fluid adjustment knob for minor and/or temporary flow control. This will extend the life of the fluid needle and tip.

25. What are the components of siphon and gravity feed systems?

Typical siphon and gravity feed systems consist of; a siphon feed or gravity feed spray gun with cup, an air compressor (not shown), a combination filter/air regulator and air hoses. (See Figure 12)

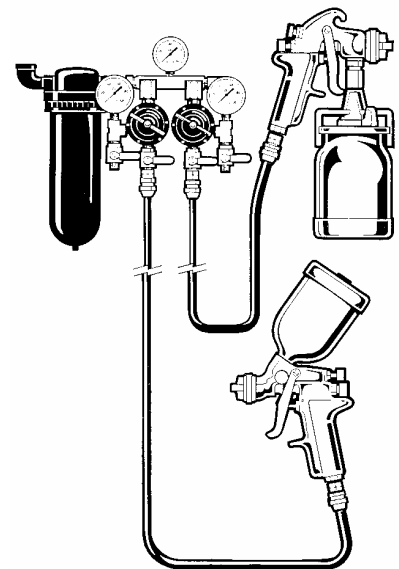

Figure 12 - Siphon Feed and Gravity Feed System Components

OPERATION

26. How is siphon and gravity feed equipment hooked up for operation?

Connect the air supply from the compressor outlet to the filter/air regulator inlet.

Connect the air supply hose from the air regulator outlet to the air inlet on the spray gun.

2. Air Atomizing Spray Guns

After the material has been reduced to proper consistency, thoroughly mixed and strained, pour it into the cup and attach the cup (suction feed) or attach the cup and fill with the coating (gravity feed).

29. How are siphon and gravity feed systems initially adjusted for spraying?

(1) Spray a horizontal test pattern (air cap horns in a vertical position). Hold the trigger open until the paint begins to run. There should be even distribution of the paint across the full width of the pattern. (see Figure 13). The fan control knob is normally adjusted fully counter-clockwise. If the distribution is not even but is symmetrical a different fluid tip may help. If the pattern is not symmetrical, there is a problem with either the air cap or the fluid tip/needle that must be corrected. Refer to the Troubleshooting Section for examples of faulty patterns to help diagnose your problem.

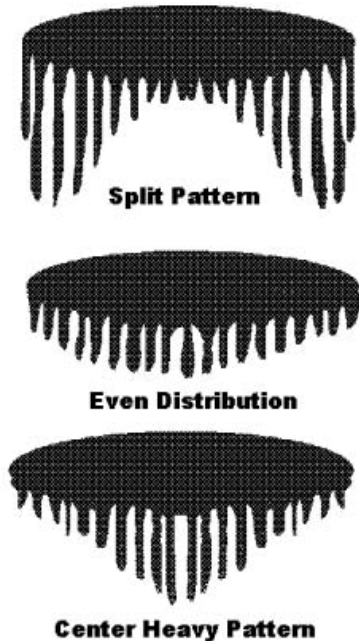

Figure 13 - Horizontal Test Pattern

(2) If the pattern produced by the above test appears normal, rotate the air cap back to a normal spraying position and begin spraying. (Example - a normal pattern with a #30 air cap will be about 9" long

when the gun is held 8" from the surface).

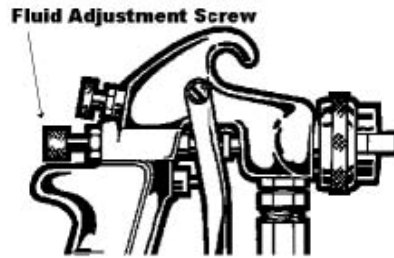
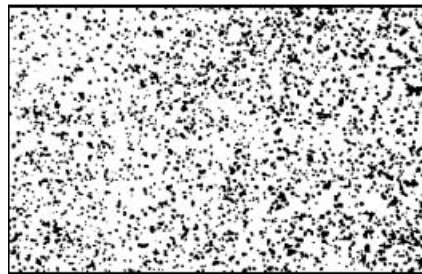

Figure 14 - Fluid Adjustment Screw

(3) With the fluid adjusting screw open to the first thread, and the air pressure set at approximately 30 psi, make a few test passes with the gun on some clean paper. If there are variations in particle size- specks and/or large globs - the paint is not atomizing properly (see Figure 19).

(4) If the paint is not atomizing properly, increase the air pressure slightly and make another test pass. Continue this sequence until the paint particle size is uniform



Uneven Distribution



Even Distribution

Figure 15- Test Patterns

(5) If the pattern seems starved for material, and the fluid adjusting screw is open wide (to the first thread), the atomization air pressure may be too high, or the material may be too heavy. Recheck the viscosity or reduce the air pressure.

(6) If the material is spraying too heavily and sagging, reduce the material flow by turning in the fluid adjusting screw (clockwise).

Remember, proper setup utilizes no more fluid and air pressure than is needed to produce the required quality and a flow rate that will meet production requirements.

28. What are the components of a pressure feed system?

A pressure feed system consists of; a pressure feed spray gun, a pressure feed tank, cup or pump, an air filter/regulator, appropriate air and fluid hoses and an air compressor. See Figure 16

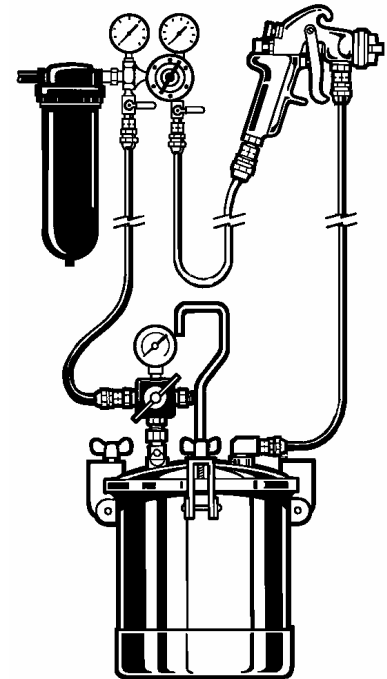

Figure 16 - Pressure Feed System Components

29. How is equipment hooked up for pressure feed spraying?

Connect the air hose from the air regulator to the air inlet on the gun.

Connect the mainline air hose to the air inlet on the tank, cup or pump. CAUTION: Do not exceed the container's maximum working pressure.

Connect the fluid hose from the fluid outlet on the tank to the fluid inlet on the gun.

2. Air Atomizing Spray Guns

30. How is the pressure feed gun adjusted for spraying?

Open spreader adjustment valve for maximum pattern size. (see figure 8)

Open fluid adjustment screw (counter clockwise) until maximum needle travel is achieved. Opening beyond that point will lessen the internal spring tension and leakage at the fluid tip may result.

31. How is the pressure feed gun balanced for spraying?

1 Using control knob on fluid regulator, set fluid pressure at 5 to 10 psi.

2 Using control knob on air regulator, set air atomization pressure at 30-35 psi.

3 Spray a test pattern (fast pass) on a piece of paper, cardboard, or wood. From that test pattern, determine if the particle size is small enough and uniform throughout the pattern to achieve the required finish quality. If particle size is too large or is giving too much texture in the finish, turn the atomization pressure up in 3 to 5 psi increments until particle size and texture of finish is acceptable.

4 Spray a part with these settings. If you are not able to keep up with the production rate required or if the finish is starved for material, increase the fluid pressure (or use a larger capacity fluid tip) with the fluid regulator control knob in 2 to 4 psi increments until required wet coverage is accomplished.

5 Remember, as you turn up the fluid pressure the particle size will increase. Once the coverage required is obtained, it will be necessary to re-adjust the atomization pressure in 3 to 5 psi increments as explained in step 3 to insure required particle size and finish texture is achieved.

6 If using HVLP, using an "Air Cap Test Kit", verify that the air cap pressure in not above 10 psi if required by a regulatory agency.

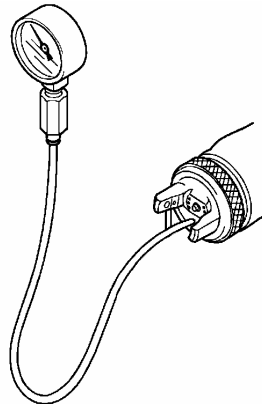

Figure 17 – Air Cap Test Kit

After establishing the operating pressures required for production and finish quality, develop a Pressure Standardization program for your finish room to follow.

32. What is a pressure standardization program?

After establishing air and fluid pressures that meet required quality and production, record the data to be used for that application for future reference. (see figure 18)

Booth # _____
Material Sprayed _____
Application _____
Viscosity _____
Fluid Temperature _____
Spray Gun Model _____
Air Cap _____ Fluid Tip _____
Air Pressure _____
Fluid Pressure _____

Figure 18 – Pressure Standardization Chart

33. How should the spray gun be held?

It should be held so the pattern is perpendicular to the surface at all times.

Keep the gun tip 8-10 inches (air spray guns) or 6-8 inches (HVLP

guns) from the surface being sprayed.

34. What is the proper technique for spray gun stroke and triggering?

The stroke is made with a free arm motion, keeping the gun at a right angle to the surface at all points of the stroke.

Triggering should begin just before the edge of the surface to be sprayed is in line with the gun nozzle. The trigger should be held fully depressed, and the gun moved in one continuous motion, until the other edge of the object is reached. The trigger is then released, shutting off the fluid flow, but the motion is continued for a few inches until it is reversed for the return stroke.

When the edge of the sprayed object is reached on the return stroke, the trigger is again fully depressed and the motion continued across the object.

Lap each stroke 50% over the preceding one. Less than 50% overlap will result in streaks on the finished surface. Move the gun at a constant speed while the trigger is pulled, since the material flows at a constant rate.

Another technique of triggering is referred to as "feathering." Feathering allows the operator to limit fluid flow by applying only partial trigger travel.

35. What happens when the gun is arced?

Arcing the stroke results in uneven application and excessive overspray at each end of the stroke. When the tip is arced at an angle 45 degrees from the surface (see figure 19), approximately 65% of the sprayed material is lost.

2. Air Atomizing Spray Guns

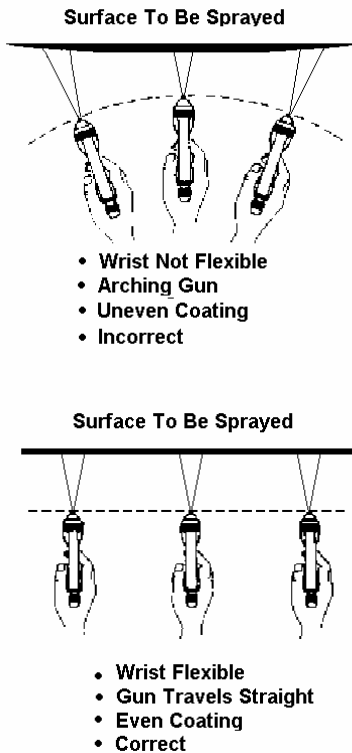

Figure 19 - Spray Techniques

36. What is the proper spraying sequence and technique for finishing applications?

Difficult areas, such as corners and edges, should be sprayed first. Aim directly at the area so that half of the spray covers each side of the edge or corner.

Hold the gun an inch or two closer than normal, or screw the spreader adjustment control in a few turns. Needle travel should be only partial by utilizing the "feathering" technique. Either technique will reduce the pattern size.

If the gun is just held closer, the stroke will have to be faster to compensate for a normal amount of material being applied to smaller areas.

When spraying a curved surface, keep the gun at a right angle to that surface at all times. Follow the curve. While not always physically possible, this is the ideal technique to produce a better, more uniform, finish.

After the edges, flanges and corners have been sprayed, the flat, or

nearly flat, surfaces should be sprayed.

Remember to overlap the previously sprayed areas by 50% to avoid streaking.

When painting very narrow surfaces, you can switch to a smaller gun, or cap with a smaller spray pattern, to avoid readjusting the full size gun. The smaller guns are usually easier to handle in restricted areas.

A full size gun could be used, however, by reducing the air pressure and fluid delivery and triggering properly.

MAINTENANCE

37. How should the air cap be cleaned?

Remove the air cap from the gun and immerse it in clean solvent. Blow it dry with compressed air.

If the small holes become clogged, soak the cap in clean solvent. If reaming the holes is necessary, use a toothpick, a broom straw, or some other soft implement. (see figure 20)

Cleaning holes with a wire, a nail or a similar hard object could permanently damage the cap by enlarging the jets, resulting in a defective spray pattern.

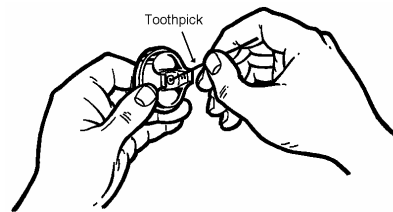

Figure 20 - Cleaning the Air Cap

38. How should guns be cleaned?

A suction or pressure feed gun with attached cup should be cleaned as follows:

Turn off the air to the gun, loosen the cup cover and remove the fluid tube from the paint. Holding the tube over the cup, pull the trigger to allow the paint to drain back into the cup.

Empty the cup and wash it with clean solvent and a clean cloth. Fill it halfway with clean solvent and spray it through the gun to flush out the

fluid passages by directing stream into an approved, closed container. All containers used to transfer flammable materials should be grounded. (Be sure to comply with local codes regarding solvent disposal.)

Then, remove the air cap, clean it as previously explained and replace it on the gun.

Wipe off the gun with a solvent-soaked rag, or if necessary, brush the air cap and gun with a fiber brush using clean-up liquid or thinner.

To clean a pressure feed gun with remote cup or tank, turn off air supply to cup or tank. Release material pressure from the system by opening relief valve.

Material in hoses may be blown back. Lid must be loose and all air pressure off. Keep gun higher than container, loosen air cap and trigger gun until atomizing air forces all material back into the pressure vessel.

A gun cleaner may be used for either type of gun. This is an enclosed box-like structure (vented) with an array of cleaning nozzles inside.

Guns and cups are placed over the nozzles, the lid is closed, the valve is energized, and the pneumatically controlled solvent sprays through the nozzles to clean the equipment.

The solvent is contained, and must be disposed of properly.

Some states' codes require the use of a gun cleaner, and it is unlawful to discharge solvent into the atmosphere.

After cleaning a spray gun in a gun cleaner, be sure to lubricate as indicated in Figure 22.

2. Air Atomizing Spray Guns

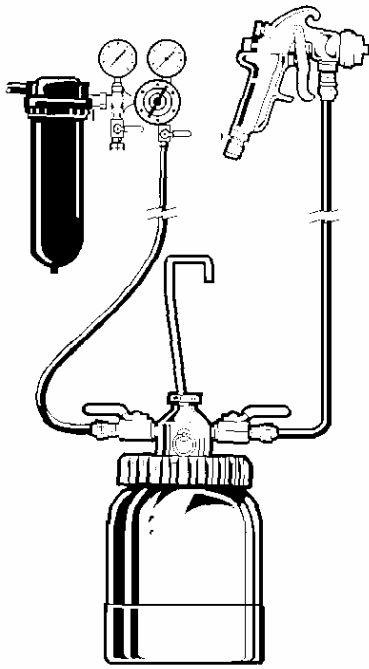

Figure 21 - Using a Hose Cleaner

Use a hose cleaner to clean internal passages of spray guns and fluid hose. This device incorporates a highly efficient fluid header, which meters a precise solvent/air mixture. The cleaner operates with compressed air and sends a finely - atomized blast of solvent through the fluid passages of the hose, the spray gun, etc.

This simple, easy to use cleaner speeds up equipment cleaning and saves solvent. Savings may be as much as 80%. It also reduces VOC emissions.

(Be sure that both the hose cleaner and gun are properly grounded.)

Where local codes prohibit the use of a hose cleaner, manually backflush the hose into the cup or tank with solvent and dry with compressed air.

Clean the container and add clean solvent. Atomization air should be turned off during this procedure. Pressurize the system and run the solvent through until clean. (Be sure to comply with local codes regarding solvent dispersion and disposal.)

Clean the air cap, fluid tip and tank. Reassemble for future use.

40. What parts of the gun require lubrication? (Figure 22)

The **A** fluid needle packing, the **B** air valve packing and the **C** trigger bearing screw require daily lubrication with a non-silicone gun lube.

The **D** fluid needle spring should be coated lightly with petroleum jelly or a non-silicone grease (ie. Lithium).

Lubricate each of these points after every cleaning in a gun washer!

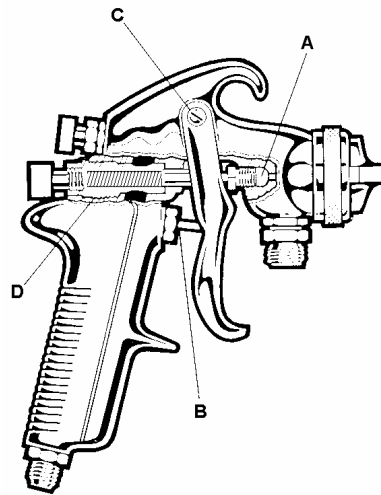

Figure 22 - Lubrication Points

2. Air Atomizing Spray Guns

Problem

Cause

Correction

Fluid leaking from packing nut

1. Packing nut loose
2. Packing worn or dry

1. Tighten, do not bind needle
2. Replace or lubricate

Air leaking from front of gun

1. Sticking air valve stem
2. Foreign matter on air valve or seat
3. Worn or damaged air valve or seat
4. Broken air valve spring
5. Bent valve stem
6. Air valve gasket damaged or missing

1. Lubricate
2. Replace or lubricate
3. Replace
4. Replace
5. Replace
6. Replace

Fluid leaking or dripping from front of pressure feed gun

1. Packing nut too tight
2. Fluid tip or needle worn or damaged
3. Foreign matter in tip
4. Fluid needle spring broken
5. Wrong size needle or tip
6. Dry packing

1. Adjust
2. Replace tip and needle with lapped or matched sets
3. Clean
4. Replace
5. Replace
6. Lubricate

Jerky, fluttering spray

Suction and Pressure Feed

1. Material level too low
2. Container tipped too far
3. Obstruction in fluid passage
4. Loose or broken fluid tube or fluid inlet nipple
5. Loose or damaged fluid tip/seat
6. Dry or loose fluid needle packing nut

1. Refill
2. Hold more upright
3. Backflush with solvent
4. Tighten or replace
5. Adjust or replace
6. Lubricate or tighten

Suction Feed Only

7. Material too heavy
8. Container tipped too far
9. Air vent clogged
10. Loose, damaged or dirty lid
11. Dry or loose fluid needle packing
12. Fluid tube resting on cup bottom
13. Damaged gasket behind fluid tip

7. Thin or replace
8. Hold more upright
9. Clear vent passage
10. Tighten, replace or clean coupling nut
11. Lubricate or tighten packing nut
12. Tighten or shorten
13. Replace gasket

2. Air Atomizing Spray Guns

Problem

Top or bottom-heavy spray pattern*



Right or left-heavy spray pattern*



Center-heavy spray pattern



Split spray pattern



Cause

1. Horn holes plugged
2. Obstruction on top or bottom of fluid tip
3. Cap and/or tip seat dirty

1. Left or right side horn holes plugged
2. Dirt on left or right side of fluid tip

*Remedies for the top, bottom, right, left heavy patterns are:

1. Determine if the obstruction is on the air cap or fluid tip. Do this by making a solid test spray pattern. Then, rotate the cap one-half turn and spray another pattern. If the defect is inverted, obstruction is on the air cap. Clean the air cap as previously instructed.
2. If the defect is not inverted, it is on the fluid tip. Check for a fine burr on the edge of the fluid tip. Remove with #600 wet or dry sand paper.
3. Check for dried paint just inside the opening. Remove paint by washing with solvent.

1. Fluid pressure too high for atomization air (pressure feed)
2. Material flow exceeds air cap's capacity
3. Spreader adjustment valve set too low
4. Atomizing pressure too low
5. Material too thick

1. Fluid adjusting knob turned in too far
2. Atomization air pressure too high
3. Fluid pressure too low (pressure feed)

Correction

1. Clean, ream with non-metallic point (ie. Toothpick)
2. Clean
3. Clean

- 1.
2. Clean, ream with non-metallic point (ie. Toothpick)
3. Clean

1. Balance air and fluid pressure
Reduce spray pattern width
2. Thin or reduce fluid flow
3. Adjust
4. Increase pressure
5. Thin to proper consistency

1. Back out counter clockwise to achieve proper flow
2. Reduce at regulator
3. Increase fluid pressure
4. Change to a larger tip

2. Air Atomizing Spray Guns

Problem

Starved spray pattern

Cause

1. Inadequate material flow
2. Low atomization air pressure (suction feed)

Correction

1. Back fluid adjusting screw out to first thread or increase fluid pressure
2. Increase air pressure and rebalance gun

Unable to form round spray pattern

1. Fan adjustment stem not seating properly

1. Clean or replace

Dry spray

1. Air pressure too high
2. Material not properly reduced (suction feed)
3. Gun tip too far from work surface
4. Gun motion too fast

1. Lower air pressure
2. Reduce to proper consistency
3. Adjust to proper distance
4. Slow down

Excessive overspray

1. Too much atomization air pressure
2. Gun too far from surface
3. Improper technique (arcing, gun speed too fast)

1. Reduce pressure
2. Use proper gun distance
3. Use moderate pace, parallel to work surface

Excessive fog

1. Too much, or too fast-drying thinner
2. Too much atomization air pressure

1. Remix properly
2. Reduce pressure

Will not spray

1. No pressure at gun
2. Fluid pressure too low (internal mix cap with pressure tank)
3. Fluid tip not open enough
4. Fluid too heavy (suction feed)
5. Internal mix cap used with suction feed
6. Pressure feed cap/tip used with suction feed

1. Check air lines
2. Increase fluid pressure at tank
3. Open fluid adjusting screw
4. Reduce fluid or change to pressure feed
5. Change to external mix air cap
6. Use suction feed cap/tip

3. Material Containers

Introduction

All spray painting systems - from the smallest brush to the most sophisticated finishing system - must have containers to hold the material being applied.

Material container types and sizes vary considerably, depending on the kind of spraying system being used.

This chapter will discuss these containers, their particular applications, their construction and maintenance.

1. What are material containers?

Any container which serves as a material supply reservoir for the spray gun. These containers are usually made of metal or plastic with capacities of 1/2 pint or more.

2. What are the types of material containers?

There are three common types of cups which attach to the gun itself: Siphon, Gravity and Pressure.

There are also remote pressure cups and tanks, which are located away from the gun. See Page 4 for types of guns and systems.

3. Where are cup container used?

Cup containers are typically one quart or less, and are used where relatively small quantities of material are being sprayed.

4. How are material feed cups attached to lid assemblies?

Cups are attached using a lid assembly (sometimes called a cup attachment) that either clamps **A** or screws **B** onto the cup container. (see Figure 1) Some lid assemblies are detachable from the gun, while others are integral parts and do not detach from less expensive models.

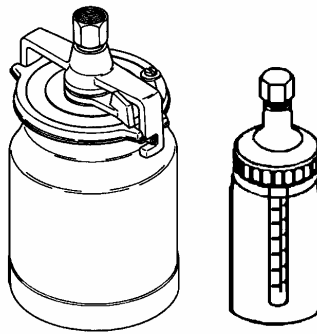

A B
Figure 1 - Cup Attachment Styles

5. What capacity does a pressure feed cup have?

A pressure feed cup can have a one or two quart capacity.

Anything larger is considered a pressure feed tank, which may be positioned some distance from the gun.

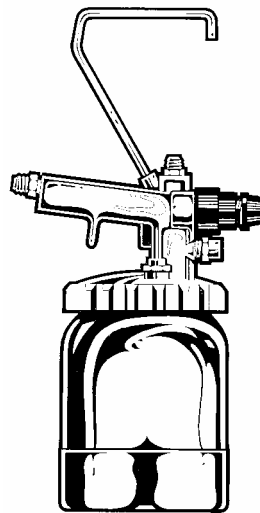

Figure 2 - Regulated 2 Qt. Pressure Cup

6. How do pressure feed tanks work?

Pressure feed tanks are closed containers, ranging in size from about two gallons to 60 gallons. They provide a constant flow of material, under constant pressure, to the spray gun.

The tank is pressurized with clean, regulated, compressed air, which forces the fluid out of the tank through the fluid hose to the gun.

The rate of fluid flow is controlled by increasing or decreasing the air pressure in the tank.

A typical pressure feed tank consists of; **A** the shell, **B** a clamp-on lid, **C** the fluid tube, **D** the fluid header, **E** regulator, **F** gauge, **G** a safety relief valve, and **H** agitator.

Pressure feed tanks are available with either top or bottom fluid outlets, and with various accessories.

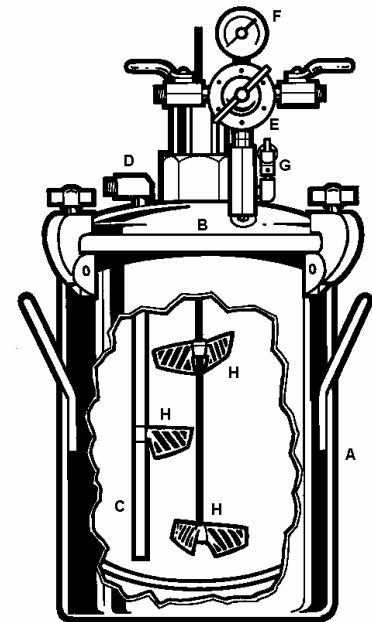

Figure 3 - Pressure Feed Tank

7. Where are pressure feed tanks recommended?

Pressure feed tanks provide a practical, economical method of material feed to the gun over extended periods of time.

They are mostly used in continuous production situations, because the material flow is positive, uniform and constant.

Tanks can be equipped with agitators (see Figure 3) that keep the material mixed and in suspension.

3. Material Containers

8. When is an agitator used in a pressure feed tank?

When the material being used has filler or pigment that must be kept in motion to keep its particles in proper suspension. An agitator can be hand, air or electrically driver

9. What is a single regulated tank?

This is a pressure feed tank with one air regulator controlling only the pressure on the material in the tank.

An extra-sensitive regulator is available for use with lower fluid flow and/or lower viscosity material where precise control is needed.

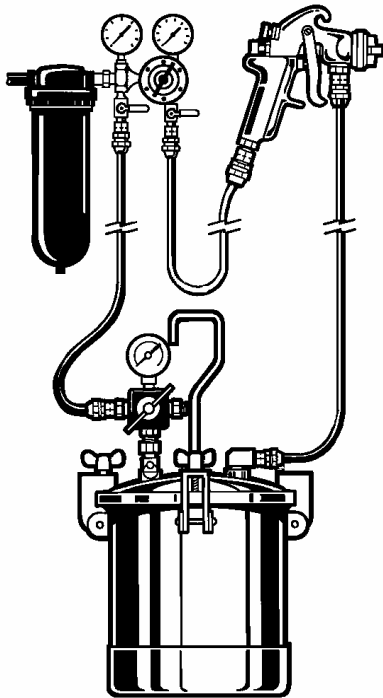

Figure 4 - Single Regulated Tank

10. What is a double regulated tank?

This is a pressure feed tank equipped with two air regulators.

One provides regulation for the air pressure on the material in the tank (thereby controlling fluid flow). The other controls atomization air pressure to the spray gun.

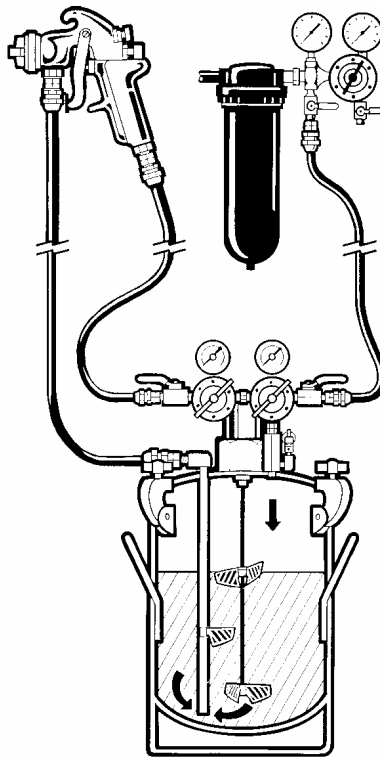

Figure 5 - Double Regulated Tank

11. What are code and non-code pressure tanks?

Code tanks are manufactured to rigid standards as specified by the American Society of Mechanical Engineers. (ASME) Each step of manufacture is closely controlled, and welding of the shell is certified. Code tanks are designed to withstand pressures up to 80 or 110 psi.

Non-code tanks are normally restricted to 3 gallons in size or less. Due to the type of construction, non-code tanks are rated at 80 psi or less.

12. What materials are used to construct pressure feed tanks?

The smaller, non-code, light-duty tanks are made of plated steel and have lower inlet pressure restrictions.

The heavy-duty, ASME-code tanks are made of galvanized or 300 series stainless steel. They also have pressed or stainless steel lids with forged steel clamps.

When abrasive or corrosive materials are being sprayed, the tank shell is coated or lined with a special material, or a container insert is used.

13. What are container inserts?

They are liners that are placed inside the tank to hold the material, keeping it from direct contact with the tank walls. They are made of disposable polyethylene.

Using inserts reduces tank cleaning time and makes color changeover easier. They also allow multiple batches of material to be mixed in advance.

You may want to consider stainless steel "Inner containers" when using ceramics or corrosive materials.

Another option to consider is putting the coating container directly into the tank if room allows. Be sure that the tank "pickup tube" does not touch the bottom of the coating container inserted into the tank.

14. When would you use a bottom outlet tank?

(1) When you are using more viscous materials.

(2) When continuous, steady pressure is required, such as when feeding plural component proportioning equipment.

(3) When you wish to use all the material in the tank and you are not using an insert.

15. What would I use if I have difficulty accurately setting lower fluid pressures?

An extra-sensitive regulator is available for use with lower fluid flow and/or lower viscosity materials where precise control is needed.

4. Hoses & Connections

Introduction

The various types of hose used to carry compressed air and fluid material to the spray gun are important parts of the system. Improperly selected or maintained hose can create a number of problems. This chapter will review the different kinds of hose and fittings in use, provide guidance in selecting the proper types for the job and cover the maintenance of hose.

1. What types of hose are used in spray painting?

There are two types; air hose - used to transfer compressed air from the air source to the gun, and fluid hose - used only in pressure feed systems to transfer the material from its container to the spray gun.

(NOTE: Do *not* use air hose for solvent-based materials.)

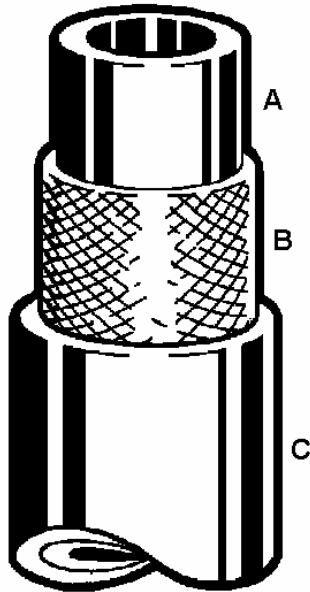

Figure 1 - Basic Hose Construction

2. How is hose constructed?

Binks/DeVilbiss hose is a performance designed combination of three components; **A** Tube, **B** Reinforcement and **C** Cover.

The tube is the interior flexible artery that carries air or fluid material from one end of the hose to the other.

The reinforcement adds strength to the hose. It is located between the tube and cover, and it can be many combinations of materials and reinforcement design. Its design determines pressure rating, flexibility, kink and stretch resistance and coupling retention.

The cover is the outer skin of the hose. It protects the reinforcement from contact with oils, moisture, chemicals and abrasive objects. The cover protects the reinforcement, but does not contribute to hose performance.

Hose color coding

RED or TANair and water
GREYair w/static ground
BLACKlow pressure fluid
TANconductive

3. What type of tube is used in fluid hose?

Since the solvents in coatings would readily attack and destroy ordinary rubber compounds, fluid hose is lined with special nylon solvent-resistant material that is impervious to common solvents.

4. What sizes of fluid hose are recommended?

Type	Length	Size
General	0' - 20'	1/4" ID
Purpose	10' - 35'	3/8" ID
	35' - 100'	1/2" ID
	100' - 200'	3/4" ID

Figure 2 - Recommended fluid hose sizes

5. What sizes of air hose are recommended?

The hose from the regulator to a gun or tank should be a minimum of 5/16" ID. Tools requiring more air may need 3/8" ID hose or larger.

Type	Length	Size
Air Tools	0' - 10'	1/4" ID
General Purpose	10' - 20'	5/16" ID
	20' - 50'	3/8" ID
	50' - 100'	1/2" ID
HVLP	0' to 20'	5/16" ID
	20' - 50'	3/8" ID
	50' - 100'	1/2" ID

Figure 3 - Recommended air hose sizes

6. What is pressure drop?

This is the loss of air pressure due to friction (caused by air flow) between the source of the air and the point of use. As the air travels through the hose or pipe, it rubs against the walls. It loses energy, pressure and volume as it goes.

7. How can this pressure drop be determined?

At low pressure, with short lengths of hose, pressure drop is not particularly significant. As pressure increases, and hose is lengthened, the pressure rapidly drops and must be adjusted.

All air hose is subject to pressure loss or drop. For example, 1/4" pressure drop is 1 psi per foot and 5/16" is 1/2 psi per foot. This pressure loss may result in poor atomization.

Too often, a tool is blamed for malfunctioning, when the real cause is an inadequate supply of compressed air due to an undersized ID hose.

For optimum spray gun results, the following is recommended: up to 20 ft - 5/16" I.D. only over 20 ft - 3/8" I.D.

4. Hoses & Connections

8. How are hoses maintained?

Hoses will last a long time if they are properly maintained.

Be careful when dragging hose across the floor. It should never be pulled around sharp objects, run over by vehicles, kinked or otherwise abused. Hose that ruptures in the middle of a job can ruin or delay the work.

Proper hose cleaning techniques are covered on Pages 11 and 12.

The outside of both air and fluid hose should be occasionally wiped down with solvent. At the end of every job, they should be stored by hanging up in coils.

9. What kinds of hose fittings are available?

Permanent, crimp type or reusable fittings are used to connect hoses to air sources or to spray equipment.

10. What kinds of hose connections are available?

Although there are many different styles, the two most common are the threaded and the quick-disconnect types.

Remember that elements added to any hose, such as elbows, connectors, extra lengths of hose, etc., will cause a pressure drop.

On HVLP systems, quick-disconnects must have larger, ported openings to deliver proper pressure for atomization. Because of normal pressure drop in the devices, they are not recommended for use with HVLP.

11. What is a threaded-type connection?

This is a common swivel-fitting type that is tightened with a wrench.

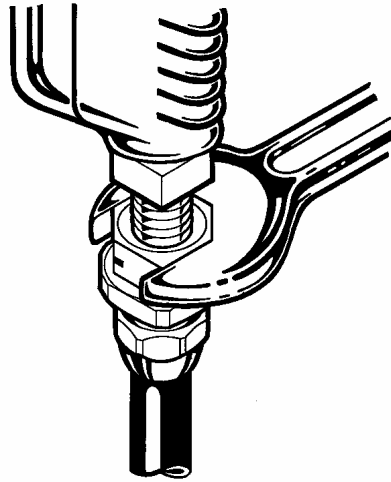

Figure 4 - Threaded-Type Connection

12. What is a quick-disconnect type connection?

This is a spring-loaded, male/female connection system that readily attaches and detaches by hand. No tools are required.

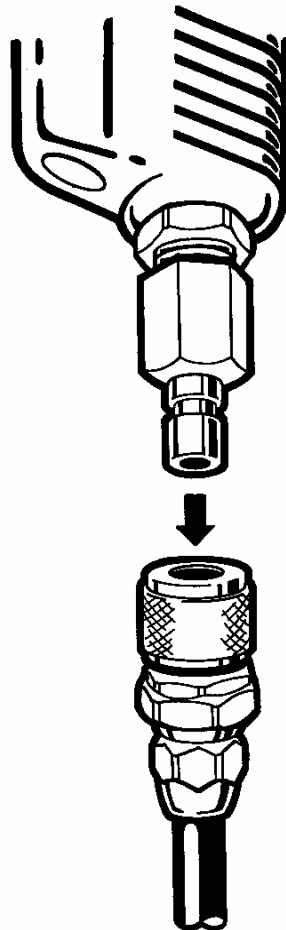

Figure 5 - Quick-Disconnect Type Connection

Care should be taken when selecting a quick, detachable air connection. Due to design, most Q.D. connections result in significant pressure drop. This can adversely affect spray guns with higher consumption air caps such as HVLP.

5. Air Control Equipment

Introduction

The control of the volume, the pressure and the cleanliness of the air entering the spray gun are of critical importance to the performance of the system.

Following some key installation principles will help decrease the risk of contaminants. For example, it's important to use the right size air compressor for your application. An overworked air compressor can produce a significant amount of dirt and oil. Additionally, proper piping is very important to help prevent condensation from forming within the line and contaminating the air supply.

This chapter examines the various types of equipment available to perform these control functions.

1. What is air control equipment?

Any piece of equipment installed between the air source and the point of use that modifies the nature of the air stream.

2. Why is air control equipment necessary?

Raw air, piped directly from an air source to a spray gun, is of little use in spray finishing. Raw air contains small, but harmful, quantities of water, oil, dirt and other contaminants that will alter the quality of the sprayed finish. Raw air will likely vary in pressure and volume during the job.

There will probably be a need for multiple compressed air outlets to run various pieces of equipment.

Any device, installed in the air line, which performs one or more of these functions, is considered to be air control equipment.

3. What are the types of air control equipment?

Air control equipment comes in a wide variety of types, but it basically all performs one or more of the following functions; air filtering/cleaning, air pressure regulation/indication and air distribution through multiple outlets.

4. How does an air filter work?

It filters out water, oil, dust and dirt before they get on your paint job. Air entering the filter is swirled to remove moisture that collects in the baffled quiet zone.

Smaller impurities are filtered out by a filter. Accumulated liquid is carried away through either a manual or automatic drain.

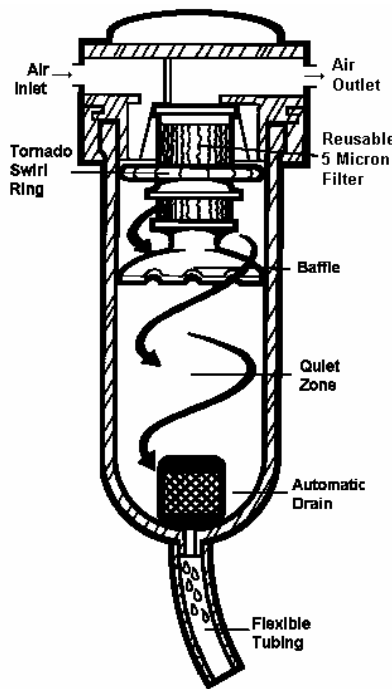

Figure 1 - Air Filter

5. What is an air regulator?

This is a device for reducing the main line air pressure as it comes from the compressor. Once set, it maintains the required air pressure with minimum fluctuations.

Regulators are used in lines already equipped with an air filtration device.

Air regulators are available in a wide range of cfm and psi capacities, with and without pressure gauges and in different degrees of sensitivity and accuracy.

They have main line air inlets and regulated or non-regulated air outlets.

6. How is an air filter/regulator installed?

Bolt **A** the air filter/regulator securely to the spray booth. (see Figure 2)

This location makes it convenient to read the gauges and operate the valves. Install the filter/regulator at least 25 feet from the (B) compressed air source. Install the (C) takeoff elbow on top of the (D) main air supply line.

Piping should slope back toward the compressor, and a (E) drain leg should be installed at the end each branch, to drain moisture from the main air line.

Use piping of sufficient I.D. for the volume of air being passed, and the length of pipe being used.

Minimum Pipe Size Recommendations*			
Compressor		Main Air Line	
HP	CFM	LENGTH	SIZE
1 1/2 - 2	6-9	Over 50'	3/4"
		Up to 200'	3/4"
3-5	12-20	Over 200'	1"
		Up to 100'	3/4"
5-10	20-40	100' - 200'	1"
		Over 200'	1 1/4"
		Up to 100'	1"
10-15	40-60	100' - 200'	1 1/4"
		Over 200'	1 1/2"
		Up to 100'	1"

Table 1

5. Air Control Equipment

*Piping should be as direct as possible. If a large number of fittings are used, larger I.D. pipe should be installed to help overcome excessive pressure drop.

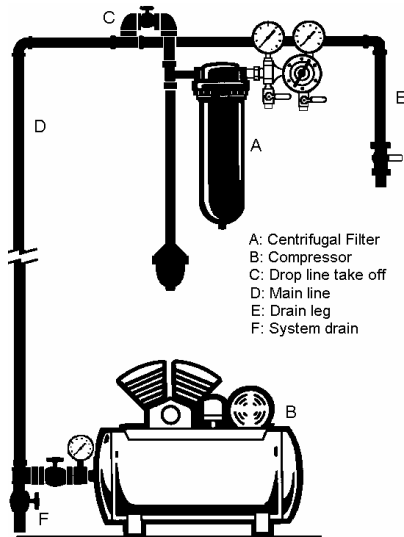

Figure 2 – Air/Filter Regulator Installation

7. How often should the filter/regulator be drained of accumulated moisture and dirt?

It depends largely on the level of system use, the type of filtration in the air system, and the amount of humidity in the air.

For average use, once-a-day drainage is probably sufficient.

For heavily-used systems, or in high humidity, drainage should occur several times daily.

Some units drain automatically when moisture reaches a predetermined level.

8. What steps should be taken if moisture passes through the filter/regulator?

Since moisture in the spray gun atomization air will ruin a paint job, it must be removed from the air supply.

When the compressed air temperature is above its dew point temperature, oil and water vapor

will not condense out into solid particles.

Check the following:

- a) Drain filter, air receiver and air line of accumulated moisture.
- b) Be sure the filter is located at least 25 feet from the air source.
- c) Main air line should not run adjacent to steam or hot water piping.
- d) Compressor air intake should not be located near steam outlets or other moisture-producing areas.
- e) Outlet on the air receiver should be near the top of the tank.
- f) Check for damaged cylinder head or leaking head gasket, if the air compressor is water cooled.
- g) Intake air should be as cool as possible.

9. What causes excessive pressure drop on the main line gauge of the filter/regulator?

- a) The compressor is too small to deliver the required air volume and pressure for all tools in use.
- b) The compressor is not functioning properly.
- c) There is leakage in the air line or fittings.
- d) Valves are partially opened.
- e) The air line, or piping system, is too small for the volume of air required. Refer to Table 1, Page 20.

6. Respirators

Introduction

Spray finishing creates a certain amount of overspray, hazardous vapors and toxic fumes. This is true, even under ideal conditions, and there is no way to avoid it entirely.

Anyone near a spray finishing operation should use some type of respirator, or breathing apparatus. This chapter covers various types of equipment for this use.

1. What is a respirator?

A respirator is a mask that is worn over the mouth and nose to prevent the inhalation of overspray fumes and vapor.

2. Why is a respirator necessary?

For two reasons:

First...some type of respiratory protection is required by OSHA/NIOSH regulations.

Second...even if it wasn't a requirement, common sense tells you that inhaling overspray is not healthy.

Overspray contains toxic particles of paint pigments, harmful dust and vapor. Exposure to any of the above is a potential health risk.

Depending on design, a respirator can remove some, or all, of these dangerous elements from the air around a spray finishing operator.

3. What types of respirators are used by spray finishing operators?

There are three primary types; the air-supplied respirator, the organic vapor respirator and the dust respirator.

4. What is an air-supplied respirator?

This type is available in both mask and visor/hood styles. Both

provide the necessary respiratory protection when using materials that are not suitable for organic vapor respirators.

The visor/hood style provides a greater degree of coverage to the head and neck of the operator.

Both styles require a positive supply of clean, breathable air as defined by OSHA (Grade D).



Figure 1 – Positive Pressure Visor/Hood

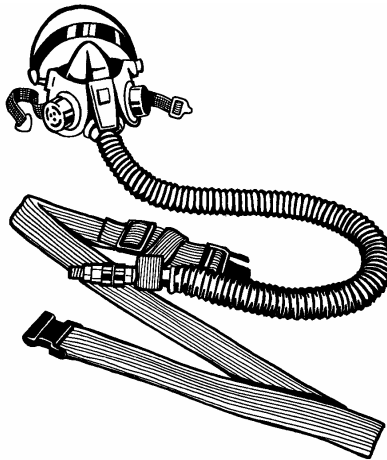

Figure 2 – Positive Pressure Mask Respirator

5. What is an organic vapor respirator and where is it used?

This type of respirator, which covers the nose and mouth, (see Figure 3) is equipped with a replacement cartridge that removes the organic vapors by chemical absorption.

Some are designed with a prefilter to remove solid particles from the air before it passes through the chemical cartridge.

The organic vapor respirator is

usually used in finishing operations with standard materials. (not suited for paints containing isocyanates).



Figure 3 - Organic Vapor Respirator

6. What is a dust respirator and where is it used?

Dust respirators are sometimes used in spray finishing but, in most applications, they are unsatisfactory. (see Figure 4)



Figure 4 - Dust Respirator

These respirators are equipped with cartridges that remove only solid particles from the air. They have no ability to remove vapors.

They are effective, however, in preliminary operations such as sanding, grinding and buffing.

NOTE:

Before using any respirator, carefully read the manufacturer's Safety Precautions, Warnings and Instructions. Many respirators are not suitable for use with isocyanates, asbestos, ammonia, pesticides, etc.

7. Air Compressors

Introduction

All air tools, spray guns, sanders, etc., must be supplied with air which is elevated to the higher pressures and is delivered in sufficient volume. The air compressor compresses air for use in this equipment and is a major component of a spray painting system. This chapter will examine the various types available.

Compressed air is measured on the basis of the volume supplied per unit of time (cubic feet per minute, or cfm) at a given pressure per square inch (psi), referred to as delivery.

Displacement is the output of air by a compressor at zero pressure, or free air delivery.

1. What is an air compressor?

An air compressor is a machine designed to raise the pressure of air from normal atmospheric pressure to some higher pressure, as measured in pounds per square inch (psi). While normal atmospheric pressure is about 14.7 pounds per square inch, a compressor will typically deliver air at pressures up to 175 psi.

When selecting a compressor:

Rule of thumb

The cubic feet per minute delivered by an electrically powered 2 stage *industrial* air compressor is 4 times the motor's horse power rating. (CFM=4xHP)

2. What types of compressors are most common in spray finishing operations?

There are two common types; the piston-type design and the rotary screw design.

Because most commercial spray finishing operations consume large quantities of compressed air at relatively high pressures, the

piston type compressor is the more commonly used.

3. How does a piston-type compressor work?

This design elevates air pressure through the action of a reciprocating piston. As the piston moves down, air is drawn in through an intake valve. As the piston travels upward, that air is compressed. Then, the now-compressed air is discharged through an exhaust valve into the air tank or regulator.

Piston type compressors are available with single or multiple cylinders in one or two-stage models, depending on the volume and pressure required.

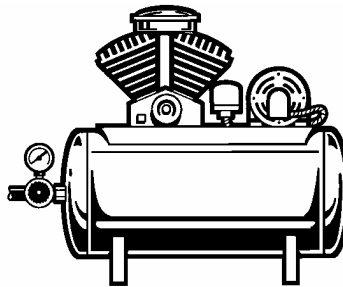

Figure 1 - Piston Type Air Compressor

4. How does a rotary screw compressor work?

Rotary screw compressors utilize two intermeshing helical rotors in a twin bore case. Air is compressed between one convex and one concave rotor. Trapped volume of air is decreased and the pressure is increased.

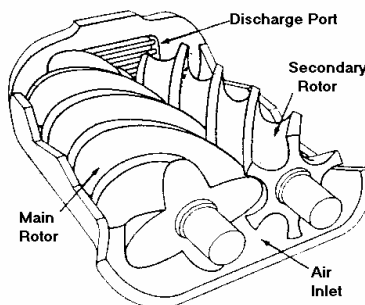

Figure 2 - Rotary Screw Air Compressor

5. What is a single stage compressor?

This is a piston-type compressor with one or more cylinders, in which air is drawn from the atmosphere and compressed to its final pressure with a single stroke.

All pistons are the same size, and they can produce up to 125 psi.

6. Where are single stage compressors used?

The application of this compressor is usually limited to a maximum pressure of 100 psi. It can be used above 100 psi, but above this pressure, two stage compressors are more efficient.

7. What is a two-stage compressor?

A compressor with two or more cylinders of unequal size in which air is compressed in two separate steps.

The first (the largest) cylinder compresses the air to an intermediate pressure. It then exhausts it into a connecting tube called an intercooler.

From there, the intermediate pressurized air enters the smaller cylinder, is compressed even more and is delivered to a storage tank or to the main air line.

Two stage compressors can deliver air to over 175 psi.

They are normally found in operations requiring compressed air of 125 psi or greater.

8. What are the benefits of two stage compressors?

Two stage compressors are usually more efficient. They run cooler and deliver more air for the power consumed, particularly in the over-100 psi pressure range.

8. Spray Booths

Introduction

Containing the overspray and keeping it out of the air and off other objects is an important consideration in a spray finishing operation. This chapter looks at the primary method of controlling overspray in the spray booth. It discusses various types of booths and details periodic maintenance.

1. What is a spray booth?

A compartment, room or enclosure of fireproof construction; built to confine and exhaust overspray and fumes from the operator and finishing system.

There are various models available, designed for particular spray applications.

Consult the National Fire Protection Association (NFPA) pamphlet #33 and the O.S.H.A. requirements for construction specifications.

2. What are the benefits of a spray booth?

A well-designed and maintained spray booth provides important advantages:

It separates the spraying operation from other shop activities, making the spraying, as well as the other operations, cleaner and safer.

It reduces fire and health hazards by containing the overspray.

It provides an area that contains residue, making it easier to keep clean. It also keeps both the operator and the object being sprayed cleaner.

In a booth equipped with adequate and approved lighting, it provides better control of the finish quality.

3. What types of spray booths are there?

There are two; the dry filter type and the waterwash type.

4. What is a dry filter type spray booth?

This booth draws overspray-contaminated air through replaceable filters and vents the filtered air to the outside.

It is the most common type of booth for most industrial applications.

It is used for spraying low-volume, slower-drying materials, and is not affected by color changes.

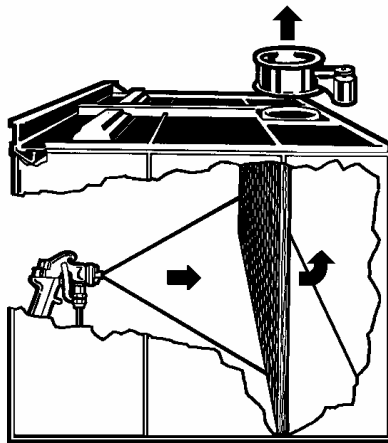

Figure 1 - Dry Filter Type Booth

5. What is a waterwash type booth?

A waterwash booth (see figure 2) actually washes the -contaminated overspray air with a cascade of water, and traps the paint solids. Fewer paint particles reach the outside atmosphere to harm the environment.

Waterwash booths are generally used when spraying more than 15 gallons of material a day.

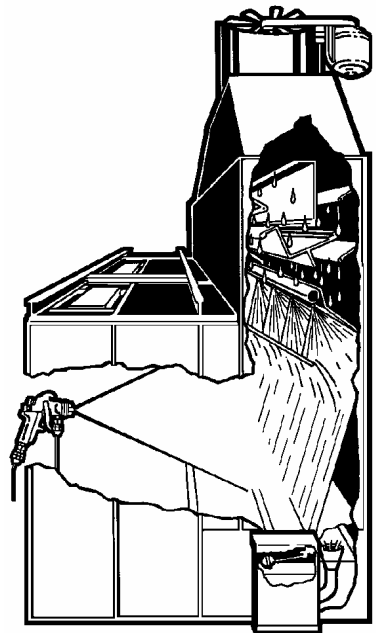

Figure 2 - Waterwash Type Spray Booth

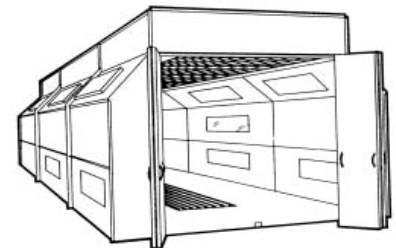

Figure 3 - Automotive Downdraft Dry Filter Booth

6. What is an exhaust fan?

A typical exhaust fan (see figure 4) consists of a motor, a multiple blade fan, pulleys and belts. It removes overspray from the spray booth area.

Contemporary exhaust fans are carefully designed to prevent overspray from coming into contact with the drive mechanism.

Blades are made of non-sparking metal, and they move the maximum volume of air-per-horsepower against resistance such as exhaust stacks, filters, etc. (See NFPA pamphlet #33.)

8. Spray Booths

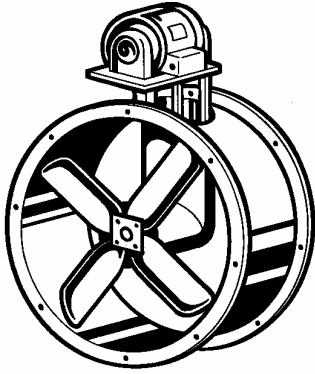

Figure 4 – Exhaust fan

7. What is air velocity?

Air velocity in a finishing operation is the term used to describe the speed of air moving through the empty spray booth.

8. What effect has air velocity on spray booth efficiency?

Air must move through the booth with sufficient velocity to carry away overspray.

Too low a velocity causes poor, even potentially dangerous working conditions, especially when the material contains toxic elements. It also increases maintenance costs.

Too high a velocity wastes power and the energy required to heat make-up air

9. What is a manometer?

It is a draft gauge which indicates when paint arrestor filters or intake filters are overloaded.

Some states and local codes require a manometer gauge on each bank of filters to comply with OSHA regulations.

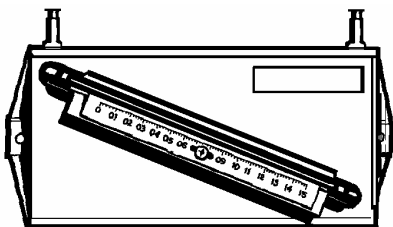

Figure 5 - Manometer

10. What does an air replacement unit do?

The volume of air exhausted from a spray booth is often equal to three or more complete air changes per hour.

Under such conditions, the temperature may become irregular and uncomfortable. Excessive dust may become a problem.

To prevent these conditions, sufficient "make-up" air must be introduced to compensate for the exhausted air.

The air replacement unit automatically supplies this "makeup" air - both filtered and heated - to eliminate the problems of air deficiency.

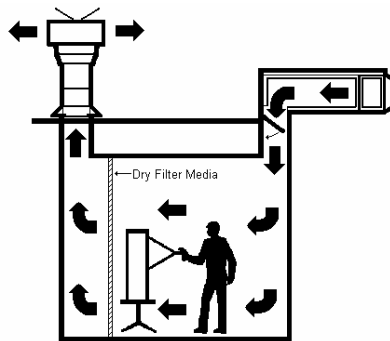

Figure 5 - Air Replacement Unit

11. What routine maintenance does a dry type spray booth require?

- The continuous flow of air through the booth eventually loads the filters with dirt and overspray. Periodically, inspect and replace them with multistage filters, designed for spray booth use. Single-stage furnace filters will *not* do the job
- Monitor the manometer readings daily, and know what a normal reading should be.
- Keep the booth free of dirt and overspray. Floors and walls should be wiped down after every job. Pick up scrap, newspapers, rags, etc.

(d) Coat the inside of the booth with a strippable, spray-on covering. When the overspray on it becomes too thick, strip and recoat.

(e) Periodically check the lighting inside the booth, and replace weak or burned out bulbs. Improper lighting can cause the operator to apply a poor finish.

12. What routine maintenance does a waterwash type booth require?

(a) Compounding of the water in this type unit is essential. Employ only booth treatment chemicals in accordance with suppliers' recommendations. The ph of the water should be between 8 and 9.

(b) Maintain the water level at the proper setting per manufacturers' specifications.

(c) Check the tank for paint buildup on the bottom, check the pump strainer to keep it clean and clear, check the air washer chamber and the nozzles in the header pipe. If the nozzles are plugged, the overspray will encroach on the wash baffle section, fan and stack.

(d) Periodically check the float valve for proper operation. Flood the sheet to be sure there is a uniform flow over the entire surface.

(e) Keep the booth interior and exhaust stack free from overspray and dirt accumulation.

8. Spray Booths

13. **What checks can be used to assure good results from a spray booth?**

- a) Keep the interior of the booth clean
- b) Maintain and replace intake and exhaust filters when necessary.
- c) Caulk all seams and cracks where dirt might enter
- d) Maintain and clean all equipment used in the booth
- e) Keep operators' clothing clean and lint-free.
- f) Perform routine maintenance above on a scheduled basis

9. Diaphragm Pumps

Introduction

Diaphragm pumps can serve several purposes in a spray system. They can be used as a transfer pump to move coatings from one container to another (ie. drum to a pressure pot).

In many cases larger diaphragm pumps can be used in a paint supply room to supply pressure to low pressure spray guns either in a dead-end system or a circulating system.

They may also be used in the spray booth to siphon directly out of a container supplying low pressure coatings to the spray gun. If required the coating could be returned to the source in a circulating system.

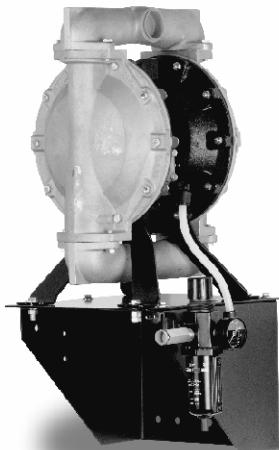

Figure 1

1. How are diaphragm pump pressures determined?

Diaphragm pumps are normally a 1:1 ratio. The maximum pressure would be limited by the pump design (ie. 100 psi) or by the available pressure to the pump.

2. What is meant by priming the pump?

Before setting working fluid pressures, start an empty pump by slowly opening the air pressure valve (or regulator) to the air motor. When the pump no longer cycles (full of coating), set the fluid pressure to the working pressure.

If the air motor receives full working pressure with an empty fluid section, the fluid section contains air and will initially run at high speed with no lubrication. This will increase the risk of damaging the fluid section.

3. How does a diaphragm pump work?

Refer to Figure 2

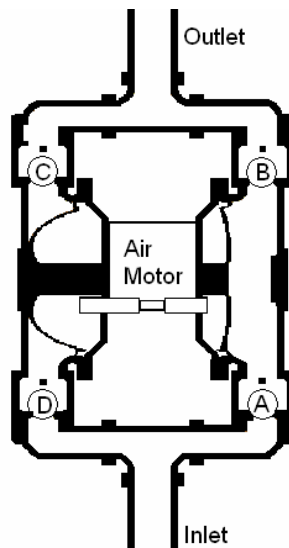

Figure 2

We will assume the pump in figure 2 is primed and the connecting rod at its maximum leftward movement and the pump is ready to move to the right. When fluid is called for, both diaphragms begin to move to the right via the rod connecting them. The four ball/seat valves behave as follows:

Ball Check A
Remains closed due to pressure in the right hand chamber.

Ball Check B
Opens to allow fluid in the right hand chamber to exit the pump

Ball Check C
Remains closed due to pressure in the upper portion of the pump

Ball Check D
Opens to allow fluid to be siphoned from the material container.

When the connecting rod causes both diaphragms to move to the left, the four ball check behave in a direction opposite to the above.

4. How do I troubleshoot a diaphragm pump air motor?

Freezing Motor

- Air exhausting from the pump tends to freeze (stall) motor
- High humidity and/or cycle rate
- Fix: Pipe exhaust away from pump

Dirt or debris in air supply

- Dirt can plug internal ports & shear air motor o-rings
- Fix: Install air filtration

Oils in air supply

- Improper or excess lubrication can cause air motor o-rings to swell and stall the pump
- Fix: Following manufacturers recommendation for lubrication

Water in air supply

- Water can wash out factory installed lubricant, leading to pump failure
- Fix: Install proper filtration

9. Diaphragm Pumps

Product discharged from air exhaust when idle

Check for diaphragm rupture

- Check tightness of diaphragm nut

Pump blows air out main air exhaust when idle

- Check "U" cups on spool in major valve
- Check valve plate and insert for wear
- Check sleeve and "O" ring on diaphragm connecting rod
- Check "O" ring on piston for wear

6. How do I troubleshoot a diaphragm pump wet section?

Leaking Clamps

- Old/worn clamps do not produce a good seal
- Leaking material can be an environmental issue
- Note: Most pumps use bolted construction rather than clamps and are less prone to leakage

Clogged Checks

- Checks cannot seat properly. Fluid will be reduced or eliminated
- Fix: Clean or replace check assembly

Fluid Compatibility

- Incompatibility can reduce life of pump
- **Danger:** Aluminum pumps may violently react with materials containing HHC (Hologenated Hydrocarbon) solvents, ie. Carbon Tetrachloride.

Under Sizing

- Pump cannot meet application requirements - shorter pump life. Undersizing typically causes high cycle rates.

Pump will not prime or meet delivery requirements

- Suction line blocked or undersized, clogged ball seats
- Suction line too long
- Suction line pulling material too far above top of fluid level

Air bubbles in product discharge

- Check connections of suction plumbing
- Check "O" rings between intake manifold and fluid caps
- Check tightness of diaphragm nut

Low output volume

- Check air supply
- Check for plugged outlet hose
- Pump mounted in vertical position?
- Check for pump cavitation - Suction pipe minimum 1/2" and non-collapsible. Cavitation will occur when the material is exiting the pump faster than it can be drawn in.
- Check all intake & suction joints - Must be airtight Use **PTFE** tape or sealant if necessary
- Check for sticking or improperly seating check valves.

10. High Pressure Spraying

Introduction

High pressure spray equipment will typically use between 300 and 4000 psi of fluid pressure. Low pressure equipment (air spray and HVLP) typically use 5-30 psi. When high volume applications and heavy film builds are called for, high pressure equipment excels.

Airless and air assist airless spray guns are used in high pressure finishing. Also required is a pump capable of delivering the pressures required for high pressure guns.

Other equipment concerns are hoses, regulators, filters, heaters and any other equipment that is subjected to the pressures being used and must be rated to handle the pressure.

1. What are the advantages of High Pressure Finishing?

- Speed of Application
Due to the high flow rates, H.P. equipment will be considerably faster than L.P. equipment
- Improved Transfer Efficiency
- Little or no air in the spray pattern
- Sprays Most Coatings
- Cost for high volume and high film build applications

2. What are the disadvantages of High Pressure Finishing?

Safety issues must be addressed. More training is required. Limited equipment flexibility.

Unlike low pressure equipment, cup guns, feathering the trigger and pattern adjustment are not available

- Higher Initial Costs
H.P. equipment must be able to handle the higher pressures used. In addition, pumps are required to generate the pressures.
- Not For Small Quantities
H.P. equipment flow rates are generally rated in gallons per

minute, L.P. equipment in ounces per minute.

- **Plugging Tips**
Due to the small opening in the fluid tip, plugging is not uncommon in H.P. equipment. Treatment and prevention for plugging may be found in the troubleshooting section of this manual.

- Heat may be required for high solids coatings

When using today's higher solid materials, heating of the material to lower the viscosity may be required to achieve the atomization required.

- **Not For Fine Finish**
The atomization capabilities of H.P. equipment will not allow it to obtain an automotive finish. Acceptability will depend on the finish standards of the product being sprayed as well as the characteristics of the coating.

Safety

3. What are the safety concerns with H.P. equipment

- **Skin Injection**
H.P. equipment has the capability of injecting coating into fingers, hands, etc.

Follow all safety instructions included with the equipment. Use tip guards and trigger locks where appropriate

- **Supporting Equipment**
Insure that all supporting equipment is rated for the pressures that could be generated. Use the maximum pump pressure as a guide.

- **Respirators**



Figure 1

Use the appropriate protection device as listed in the coating's Material Safety Data Sheet (MSDS)

Warning:

INJECTION HAZARD

Spray from the gun, hose leaks, or ruptured components can inject fluid into your body and cause extremely serious injury, including poisoning or the need for amputation.

Splashing fluid in eyes or on skin can also cause a serious injury.

Fluid injected into the skin might look like just a cut, but is a serious injury and should be treated as such.

GET IMMEDIATE MEDICAL ATTENTION. INFORM THE PHYSICIAN WHAT TYPE OF MATERIAL WAS INJECTED.

Do not point the spray gun at anyone or any part of the body.

Do not put fingers or hand over the spray tip.

Do not stop or detect fluid leaks with a rag, hand, body or glove.

Do not use a rag to blow back fluid. **THIS IS NOT AN AIR SPRAY GUN.**

Be sure the trigger operates safely before spraying.

Engage the gun safety when not spraying.

ALWAYS RELIEVE THE PRESSURE WHENEVER WORKING ON THE SPRAY GUN.

Tighten all fluid connections before operating equipment.

Check all hoses, tubes, and couplings daily. Replace all worn, damaged, or loose parts immediately.

11. Airless and Air Assist Airless Guns

Introduction

High pressure spraying requires the use of spray guns that can withstand the pressures associated with the pressures delivered via piston pumps.

Airless and Air Assisted Airless are currently available in both manual and automatic models.

Some models may have maximum pressures below the pressures the pumping system may deliver. Consult your distributor to determine your pump

1. What is an airless gun?

An airless gun uses high hydraulic pressure to force coating through a small elliptical shaped orifice to atomize.

2. What do I need to know to choose an airless fluid tip?

The following will determine pattern size and atomization,:

- Fluid tip orifice shape
- Fluid tip orifice area
- Fluid viscosity
- Fluid pressure

Fluid tips for airless guns are sized based on an equivalent circular opening. As an example, a .015" opening can take on many different shapes, thus different pattern sizes and atomization levels. For example, Table 1 shows 7 different .015 fluid tips available for one model of an airless spray gun.

The shape of the opening is the variable that determines the pattern size.

An additional note: The larger pattern sizes are the result of a tip opening that is more slender than the shorter pattern tip. This will give a larger pattern size at the expense of more frequent tip plugging and shorter tip life.

113-01506	.015	4" – 6"
113-01508	.015	6" – 8"
113-01510	.015	8" – 10"
113-01512	.015	10" – 12"
113-01514	.015	12" – 14"
113-01516	.015	14" – 16"
113-01518	.015	16" – 18"

Table 1 – Sample .015 tips

3. How does an airless gun operate?

An airless spray gun uses high hydraulic fluid pressure generated by a pump. The fluid is forced through a small elliptical shaped orifice (fluid tip or fluid nozzle) to generate the pattern.



Figure 1 – Airless Spray Gun

4. What is an air assist airless gun?

When an airless gun (see Figure 4) is set up with pressures under 2000 psi, the possibility of incomplete atomization increases. The net result is a pattern that has “tails” at the top and bottom. If sprayed with such a pattern, one would see a stripe at the top and bottom of each pass (see figure 2).



Figure 2 – Incomplete Atomization



Figure 3 – Air Assist

An air cap similar to a conventional or HVLP spray gun is added to a high pressure spray gun, thus the name Air Assist Airless. Set the pressure on the assist air is set high enough to eliminate the tails. (see figure 3)



Figure 4 – Air Assist Gun

12. Two Ball Piston Pumps

Two Ball Piston Pumps

Introduction



Figure 1 – Two Ball Piston Pump

A pump is required to generate the pressures required for airless and air assist airless spray guns.

The most common pump used to supply high pressure spray guns is an air driven two ball piston pump.

1. How are piston pump pressures determined?

Pump ratios are determined by the size of the piston in the air motor compared to the size of the piston in the fluid section.

The maximum pump pressure available from a pump is the ratio of the pump multiplied by the maximum air inlet pressure as stated in the pump literature.

As an example, consider a piston pump with an 8" air motor and a 2" fluid section.

8" = 50.24 square inch area
2" = 3.14 square inch area

$50.24/3.14 = 16:1$ ratio

If the pump had a maximum air inlet pressure of 100 psi, the maximum fluid pressure the pump could generate is 1600 psi.

2. What ratio do I need for my spray gun?

It is generally recommended that the maximum usable pressure is approximately 60-70% of the maximum pump pressure. A spray gun that requires 1000 psi of fluid pressure would need approximately an 18:1 pump (60% times 1800 psi would give 1080 psi of working pressure).

Other factors that influence ratio selection include:

- Gun distance from pump (pressure drop)
- Circulation requirements (if used)
- Viscosity of material
- Size of fluid tip in gun
- Pipe layout

3. What is meant by priming the pump?

Before setting working fluid pressures, start an empty pump by slowly opening the air pressure valve (or regulator) to the air motor. When the pump no longer cycles (full of coating), adjust the regulator to set the fluid pressure to the working pressure.

If the air motor receives full working pressure with an empty fluid section, the fluid section contains air and will initially run at high speed with no lubrication. This will increase the risk of friction/heat damaging the packings and/or fluid section.

4. How does a Two Ball Fluid Section work?

The fluid section is connected to the air motor. As the air motor moves up (1 stroke) it brings the displacement rod up. As the air motor moves down, it pushes the displacement rod down.

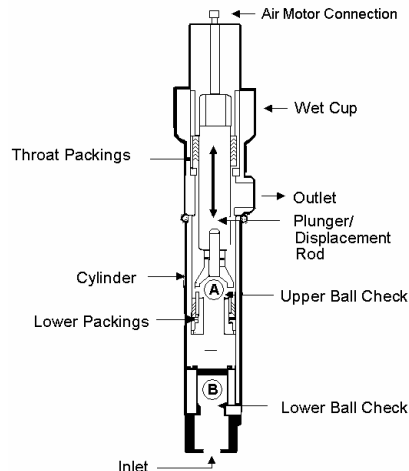

Figure 2 – 2 Ball Fluid Section

During the upstroke, the lower ball (B) raises allowing coating to enter the lower portion of the fluid section. Coating in the upper portion of the fluid section is pushed out of the outlet. The upper ball (A) remains closed. (see to Figure 2)

During the downstroke, the lower ball remains closed. The upper ball is forced open allowing coating from the lower portion of the pump to enter the upper portion pushing coating out of the outlet.

If the pump is designed properly, 50 percent of the pumps output will be delivered on each stroke. (one upstroke, one downstroke). Note that with most 2 ball pumps all of the coating siphoned into the pump for the complete cycle enters the fluid section on the upstroke.

5. What is the purpose of the Wet Cup?

Lubrication for the upper packings is provided by a lubricant added to the "Wet Cup" at the upper portion of the fluid section. This cup is not designed to contain solvent. Solvent will evaporate, leaving the upper packings without lubricant. Throat Seal Lubricant (TSL) should be used in the wet cup.

6. What is meant by cavitation?

A pump has little difficulty pushing material through the outlet into the piping or tubing system.

If the pump cannot bring material into the pump as fast as it pushes it out, a cavity or void is created in the input area. This could result if the material is highly viscous or the siphon tube is undersized or not airtight

13. High Pressure System Setup – Dead End

Introduction

Proper setup of high pressure equipment is necessary not only for efficient operation of the equipment, but safe operation as well.

Airless and Air Assist Airless may be supplied by a dead-end system or a circulating system.

Following are instructions for a dead-end system.

1. How do I set up a simple (dead-end) high pressure system?

Refer to Figure 1 for a typical “dead end” high pressure system.

1. 2 Ball Piston Pump

Available in range of approximately 11:1 to 60:1

2. Filter/Regulator for Pump air motor
The air motor of a piston pump needs to be supplied with clean, dry air

3. Surge tank (pulsation chamber)
Eliminates pulsation that happens when the piston changes direction

4. Dual Fluid Filters
Prevents the line from being shut down when it is time to clean the filter

5. Fluid pressure gauge
Monitors the fluid pressure in the main line

6. Drop Line regulator

Allows for regulation to the required pressure of the spray gun.

2. What parameters in a “dead end” system should be of concern?

1. Use only components that can handle the pressures in the system. This includes all components in figure 1 as well as hoses, guns, fittings, etc.
2. Fluid lines must be sized adequately to prevent large pressure losses
3. When using coating materials that “settle out” or high viscosity materials that need to be heated, a circulating system may be a better option.

3. How fast or slow should my pump be cycling?

Most pumps give a flow rate per cycle as well as a flow rate for 60 cycles. A flow rate of 15 cycles per minute will keep maintenance to a minimum. As you increase cycle speed, maintenance cost will increase as well.

If you undersize a pump, high cycle rates and high maintenance costs will be the result.

4. What safety issues should be addressed in a high pressure system?

1. All components in the systems must be rated to handle the maximum pressure the pump could generate.
2. Avoid the possibility of any portion of the body being near the fluid tip whenever there is a chance of fluid leaving the tip. If you inject your skin with coating, seek medical help immediately.
3. If the gun is equipped with a trigger safety, engage it when the gun is not in use.
4. If the gun is equipped with a tip guard (duck bill), do not remove it.

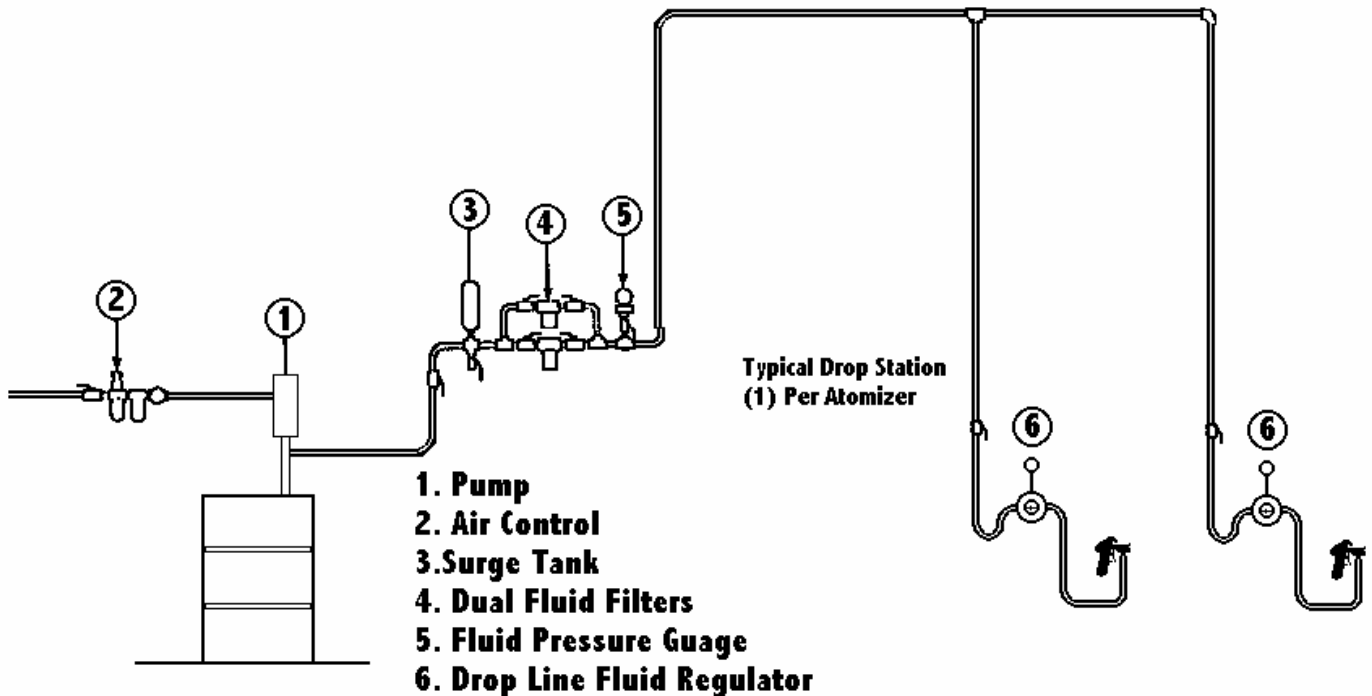

Figure 1 – Dead End High Pressure System

14. Four Ball Pumps

Introduction

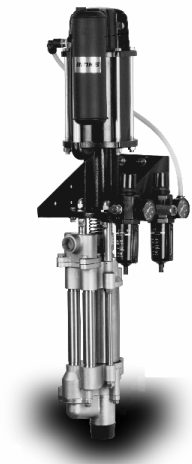

Figure 1 – Four Ball Piston Pump

A four ball pump generally is used in a “pump house” or “paint kitchen” for delivering lower pressures a long distance or high flow rates.

Pressures tend to be much lower than 2 ball pumps and are often regulated down at the point of use for air atomized spray guns.

1. What ratios are available in a four ball pump.

Due to the larger fluid section, a very large air motor would be required to achieve the typical pressures achieved with two ball pumps. Using the same air motors used in two ball pumps, four ball pumps typically top at about a 7:1 ratio.

2. How does the fluid section of a four ball pump work?

A four ball piston pump fluid section contains four ball checks that alternate open and closed during up and down strokes (refer to figure 2).

During the down stroke:
Ball checks (D) and (A) open.
Ball (A) allows fluid to exit while ball (D) allows fluid to enter the pump.
Ball checks (B) and (C) remain closed.

During the up stroke:
Ball checks (B) and (C) open.
Ball (B) allows fluid to exit while ball (C) allows fluid to enter the pump. Ball checks (D) and (A) remain closed.

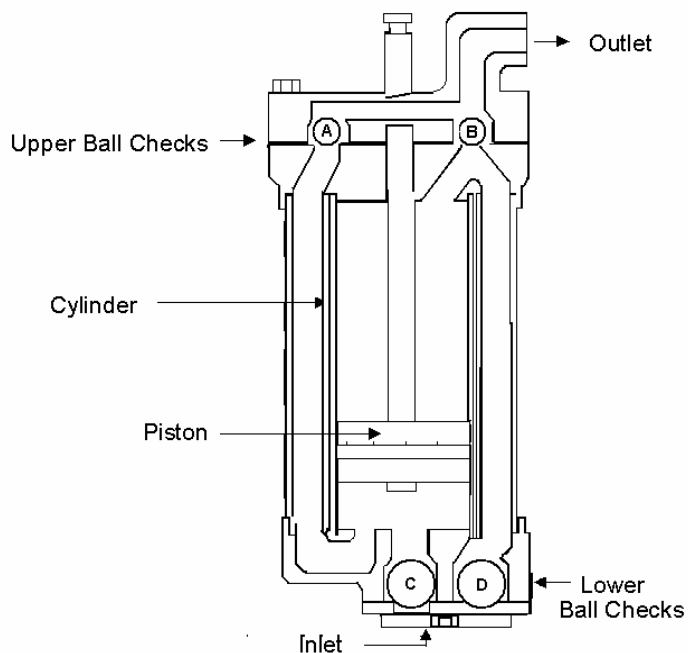

Figure 2 - Four Ball Fluid Section

15. Circulating Systems

Introduction

A circulating system delivers fluid from the pump to the spray gun and back to the pump. (see figure 1).

You should consider a circulating system:

1. When multiple stations need the same coating.
2. When you want to put a paint heater in the system (to reduce viscosity without adding solvents).
3. When you have problems with the solids of a coating "settling out".

1. What flow rates are used in a Circulating system?

Typical flow rates for solvent based materials are one foot per second (60 feet/min).

Typical water based materials use one half foot per second (30 feet/min).

Consult your Product Data Sheet or your coating supplier for recommendations for your coating.

2. How does a circulating system work?

While some circulating systems can get very complex, refer to figure 1 for a very basic circulating system

The coating leaves the fluid section of the pump and travels through hoses, pipes, etc. to the spray gun.

A valve or tee at the spray drop line returns a portion of the material back to the pump on a return line.

The materials may return to the pump inlet or into the material container.

3. What is a back pressure regulator?

Referring to figure 1, imagine the back pressure regulator (3) removed from the system and the piping is straight through back to the pump.

There would be no reason for the material to flow to the spray gun as the path of least resistance for the material is back to the pump.

By putting a back pressure regulator in the system we create a dam that allows some fluid to return to source but set up a partial blockade (back pressure) to allow material to flow to the spray gun.

The general sequence for adjusting a back pressure regulator is:

1. Set the regulator to insure that the spray guns have adequate operating pressure.
2. Adjust for proper flow rate
3. Adjust for proper pump speed

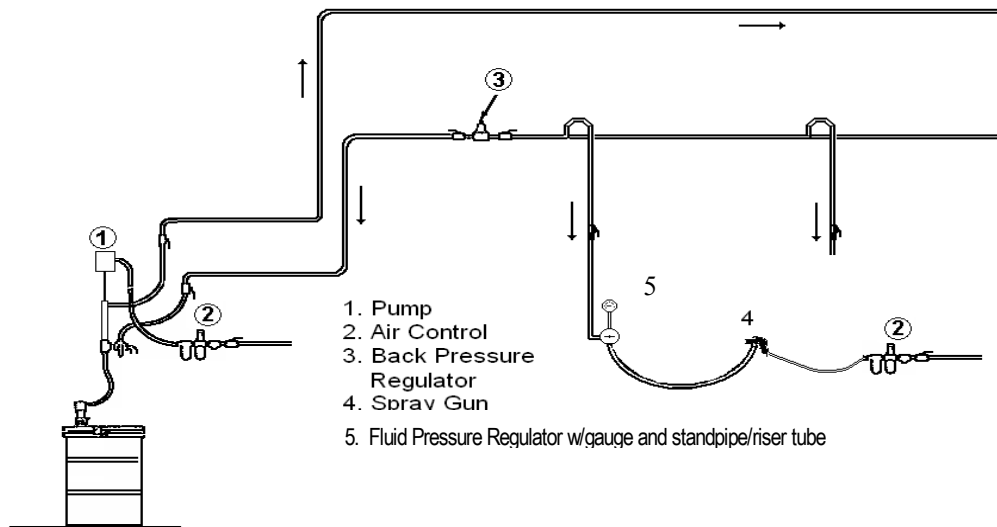

Figure 1 – Circulating System

15. Circulating Systems

4. What other components are used in a circulating system?

Downstream Fluid Regulators:

For controlling pressure at each spray gun

Surge Tanks/Chambers:

For suppressing the “wink” or pulse in the system, induced by the pump changing direction during the cycle

Heaters:

For decreasing viscosity without adding solvent and maintaining a constant viscosity

Filters:

For removing contaminants and preventing plugging gun fluid tips and spray defects. Note: Filters are located in the pressure side of the system.

Strainers:

For removing “trash” prior to entering the pump. Note: Strainers are located on the non-pressure portion of the system, normally on the end of the pump pick-up tube.

Drum Lifts/Elevators:

Allows the pump and drum lid to be raised to facilitate replacement of the drum.

Agitator:

Keeps material in suspension in the drum/container.

16. High Pressure Troubleshooting

Introduction

Problems arising in a high pressure pumping system can range from something as simple as a plugged fluid tip to a runaway pump.

Service literature that accompanies your equipment is highly recommended reading.

1. What problems can I have with my high pressure system?

Plugged airless tips:

Caution: At a minimum, lock the trigger before working on a high pressure airless fluid tip. If possible, remove the pressure to the gun.

Be cautious when cleaning the tip orifice. Use only recommended tools to clean a plugged tip.

Runaway Pump

When the material supply “runs out”, the pump will cycle at maximum speed.

A “runaway” detecting valve can be installed in the air line between the air motor and the regulator to prevent pump damage. Check your pump accessory catalog for runaway valve options.

Defective Spray Patterns

Airless:

Replace or clean the tip

Air Assist Airless:

Rotate the air cap 180 degrees. If the pattern changes, clean or replace the air cap. If the pattern did not change, clean or replace the fluid tip.

Fluid Section Problems

No Material at outlet
(Pump continually cycles)
Check material supply

Material on one stroke only.
(fast down stroke) 2 Ball
Lower ball not properly seating

Material on one stroke only.
(fast upstroke)
Worn or damaged seals

Material leakage from solvent cup
Worn or improperly adjusted upper packings.

Air bubbles in product discharge
Siphon kit improperly installed.
(not air tight)

Material on one stroke only.
(fast up or down stroke) 4 Ball
One of lower balls not properly seating.

Air Motor Problems

Air leakage out of main exhaust

Worn Insert

Replace Insert

Worn valve plate & pin assy

Replace plate & assy.

Damaged piston assy.

Replace piston assy.

Sales and Service
Through a Nationwide Network of Industrial Distributors



North American Office
Industrial Finishing
195 Internationale Blvd.
Glendale Heights, IL 60139

630.237.5000
630.237.5011 Fax

www.binks.com
www.devilbiss.com

Customer Service
1-800-992-4657

Technical Support
1-888-992-4657